

1. Part No. Expression:

SRXQ453217140KS

(a) (b) (c) (d) (e)(f)

- a) Series Code
- b) Internal Code
- c) Dimension Code
- d) Inductance Code
- e) Tolerance Code
- f) Winding Code

2. Configuration & Dimensions: (Unit-mm)

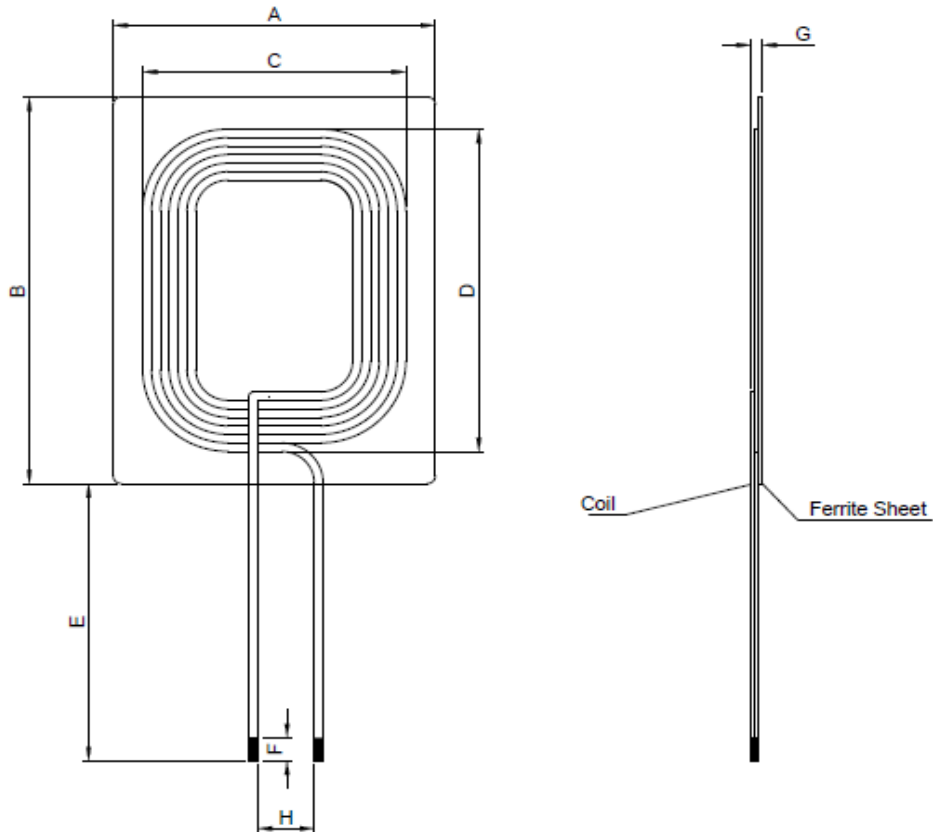

A	B	C	D	E	F	G	H
32.0 Max	45.0 Max	29.0 Ref	36.3 Ref	27.0±2.0	5.0±2.0	1.7 Max	5.0 Ref

NOTE: Specifications subject to change without notice. Please check our website for latest information.



3. Schematic:



4. Electrical Characteristics:

Inductance (uH)	Test Frequency (Hz)	DCR (mΩ)	Irms (A)
14.0±10%	1V/100K	355 Max	1.2 Max

5. General Specifications:

- a) Operating Temp.: -40°C ~ +125°C
- b) Storage Temp.: -40°C ~ +125°C (packaging)
- c) Irms: Based on temp. rise up to 40°C Max.
- d) Power Rating: 5W

6. Material List:

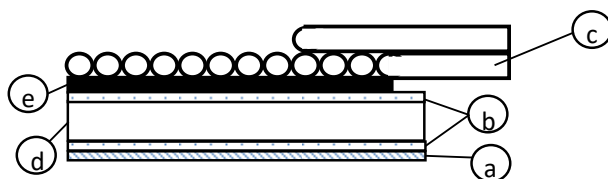

- (a) Release Film
- (b) PET Film
- (c) Wire
- (d) Ferrite Sheet (MnZn)
- (e) Adhesive

NOTE: Specifications subject to change without notice. Please check our website for latest information.