

1. Part No. Expression:

**PIC1004H1R0MF-□**

(a) (b) (c) (d) (e)(f) (g)

- (a) Series Code
- (b) Dimension Code
- (c) Type Code
- (d) Inductance Code
- (e) Tolerance Code
- (f) RoHS Compliant
- (g) Internal Control Number

2. Configuration & Dimensions :

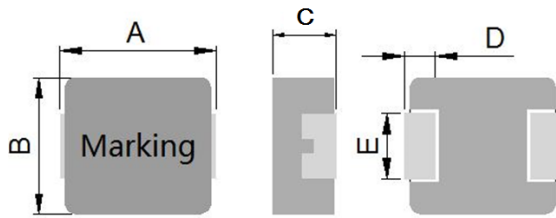

Lead Frame

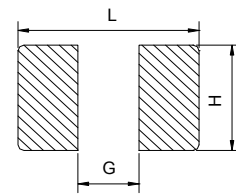

Recommended PC Board Pattern

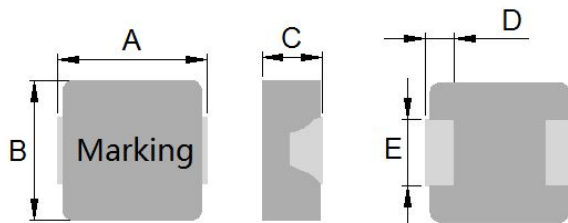

Non-Lead Frame

Note:

1. The above PCB layout is for reference only.
2. Solder paste thickness of 0.15mm and above is recommended.
3. Marking : Top row – Inductance code, Bottom row – Year/World week

Unit: mm

Series	Type	A	B	C	D	E	L	G	H
PIC1004	Lead Frame	11.0±0.5	10.0±0.3	3.8±0.2	2.3±0.3	3.0±0.3	13.6	5.4	3.5
	Non-Lead Frame								

NOTE: Specifications subject to change without notice. Please check our website for latest information.

3. Schematic

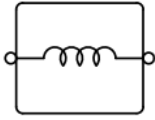

4. Material List

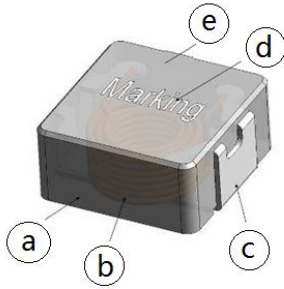

Lead Frame

- a) Core
- b) Wire
- c) Clip
- d) Ink
- e) Paint

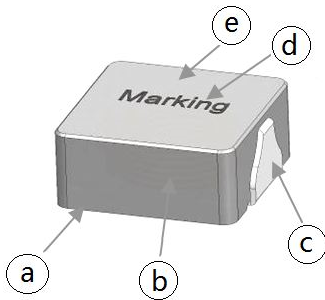

Non- Lead Frame

- a) Core
- b) Wire
- c) Solder
- d) Ink
- e) Paint

5. General Specification

- a) Test Freq. : L:100KHz/1.0V
- b) Operating Temperature: - 40°C to +125°C
- c) Storage Temperature: - 40°C to +125°C
- d) Humidity Range: 85 ± 2% RH
- e) Heat Rated Current (I<sub>rms</sub>) will cause the coil temperature rise approximately Δt of 40°C (keep 1min.)
- f) Saturation Current (I<sub>sat</sub>) will cause L<sub>0</sub> to drop approximately 30%
- g) Part temperature (Ambient + Temp. Rise): Should not exceed 125°C under worst case operating conditions
- h) Storage Condition (component in its packaging)
  - i) Temperature: - 10°C to 40°C
  - ii) Humidity: 50 - 60% RH

NOTE: Specifications subject to change without notice. Please check our website for latest information.



6. Electrical Characteristics

Part Number	Inductance L0 (uH) @ 0 A	I rms (A) Typ.	I sat (A) Typ.	DCR(mΩ) Typ. @25°C	DCR(mΩ) Max. @25°C	Type
PIC1004HR15YF	0.15±30%	43	75	0.5	0.6	Non- Lead Frame
PIC1004HR19YF	0.19±30%	36	70	0.6	0.9	Non- Lead Frame
PIC1004HR22MF	0.22	35	60	0.8	1.0	Non- Lead Frame
PIC1004HR24MF	0.24	34	60	0.8	1.0	Non- Lead Frame
PIC1004HR27MF	0.27	33	60	0.82	1.0	Non- Lead Frame
PIC1004HR30MF	0.30	32	60	0.94	1.1	Non- Lead Frame
PIC1004HR36MF	0.36	31	60	1.05	1.2	Non- Lead Frame
PIC1004HR39MF	0.39	30	60	1.1	1.3	Non- Lead Frame
PIC1004HR45MF	0.45	29	45	1.3	1.5	Non- Lead Frame
PIC1004HR47MF	0.47	28	43	1.3	1.5	Non- Lead Frame
PIC1004HR56MF	0.56	25	40	1.6	1.8	Non- Lead Frame
PIC1004HR68MF	0.68	22	39	2.4	2.7	Non- Lead Frame
PIC1004HR75MF	0.75	22	39	2.4	2.7	Non- Lead Frame
PIC1004HR88MF	0.88	20	38	2.5	2.9	Non- Lead Frame
PIC1004H1R0MF	1.00	18	36	3.0	3.3	Non- Lead Frame
PIC1004H1R2MF	1.20	17	33	3.3	3.8	Non- Lead Frame
PIC1004H1R5MF	1.50	16	33	4.0	4.6	Non- Lead Frame
PIC1004H1R8MF	1.80	14	30	5.3	6.4	Lead Frame
PIC1004H2R2MF	2.20	12	27	6.5	7.0	Lead Frame
PIC1004H2R5MF	2.50	11.5	23	7.9	8.7	Lead Frame
PIC1004H3R0MF	3.00	11.5	21	10	11.5	Lead Frame
PIC1004H3R3MF	3.30	11	20	10.8	11.8	Lead Frame
PIC1004H3R9MF	3.90	10.5	19	12.6	14.5	Lead Frame
PIC1004H4R0MF	4.00	10.2	18	13	15	Lead Frame
PIC1004H4R7MF	4.70	10	17	15.0	15.5	Lead Frame
PIC1004H5R6MF	5.60	9.0	14	17	19.3	Lead Frame
PIC1004H6R2MF	6.20	8.7	13.7	17.2	21.3	Lead Frame
PIC1004H6R8MF	6.80	8.5	13.5	17.5	23.3	Lead Frame
PIC1004H7R3MF	7.30	8.3	13.0	19.0	21.8	Lead Frame
PIC1004H8R2MF	8.20	8.0	12.5	20	22.5	Lead Frame
PIC1004H100MF	10.0	7.5	12.0	27.0	30	Lead Frame
PIC1004H150MF	15.0	6.25	10	40	45	Lead Frame

NOTE: Specifications subject to change without notice. Please check our website for latest information.



Part Number	Inductance L0 (uH) @ 0 A	I rms (A) Typ.	I sat (A) Typ.	DCR(mΩ) Typ. @25°C	DCR(mΩ) Max. @25°C	Type
PIC1004H180MF	18.0	5.5	9.0	56	62	Lead Frame
PIC1004H220MF	22.0	5.0	7.0	64	74	Lead Frame
PIC1004H270MF	27.0	4.0	6.0	86	100	Lead Frame
PIC1004H330MF	33.0	3.5	5.0	92	112	Lead Frame
PIC1004H470MF	47.0	3.0	4.5	145	167	Lead Frame
PIC1004H680MF	68.0	2.0	3.0	205	240	Lead Frame

Tolerance: M = ± 20% ; Y = ±30%

### 7. Characteristics Curves

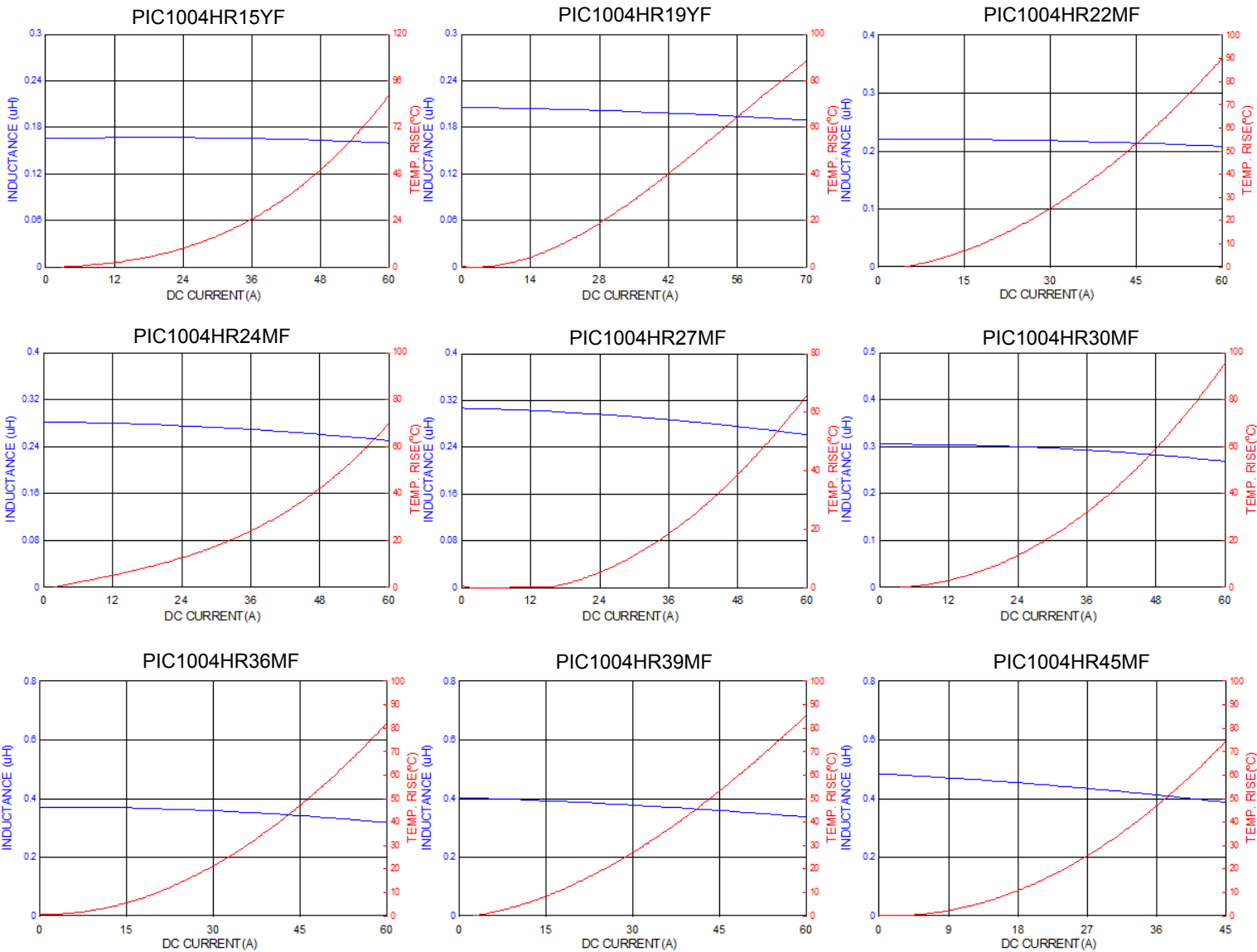

NOTE: Specifications subject to change without notice. Please check our website for latest information.



PIC1004HR47MF

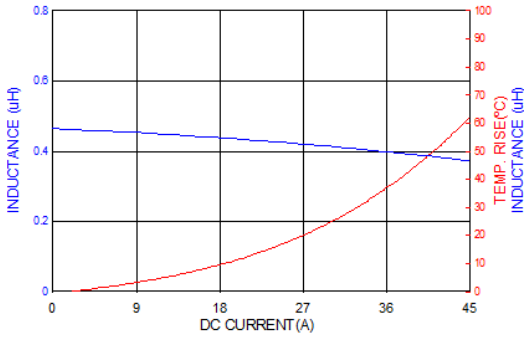

PIC1004HR56MF

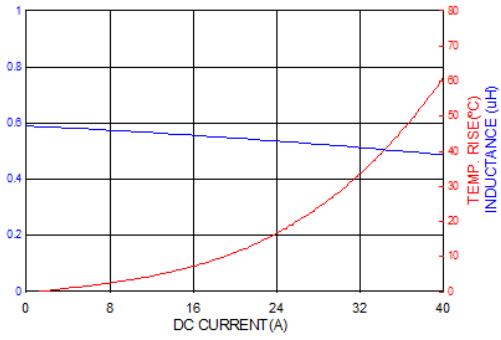

PIC1004HR68MF

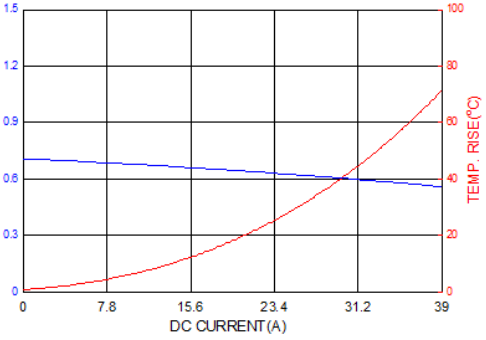

PIC1004HR75MF

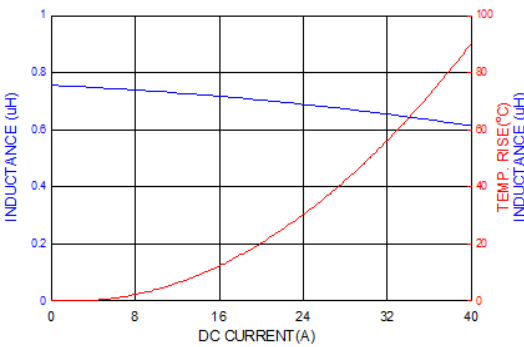

PIC1004HR88MF

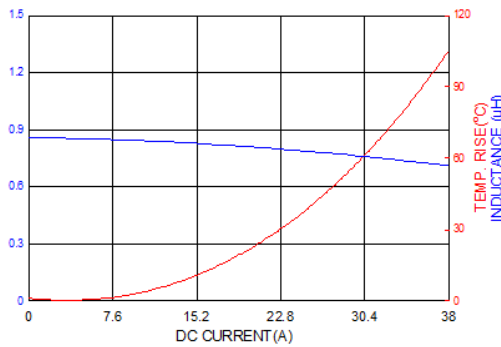

PIC1004H1R0MF

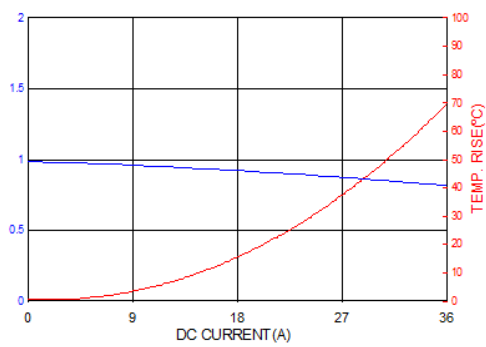

PIC1004H1R2MF

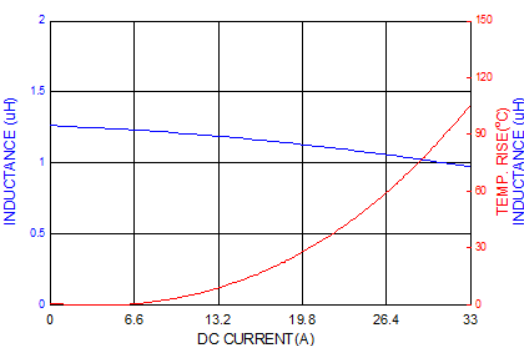

PIC1004H1R5MF

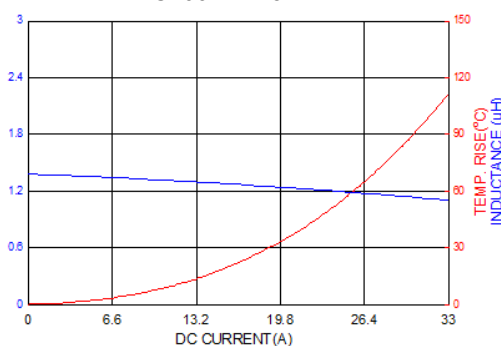

PIC1004H1R8MF

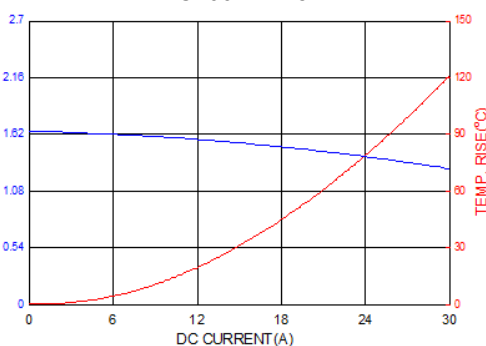

PIC1004H2R0MF

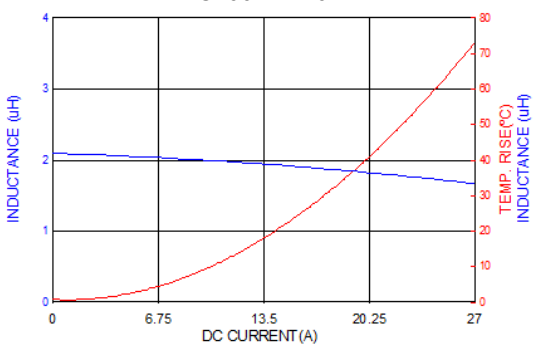

PIC1004H2R5MF

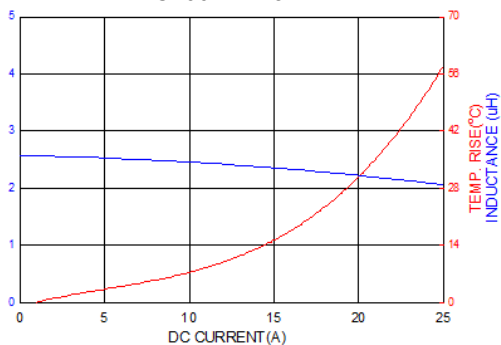

PIC1004H3R0MF

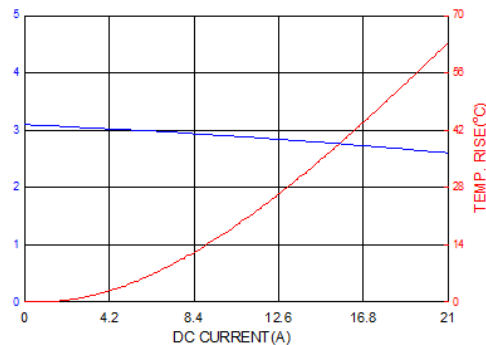

NOTE: Specifications subject to change without notice. Please check our website for latest information.



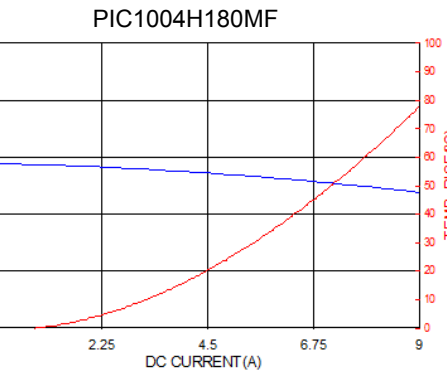
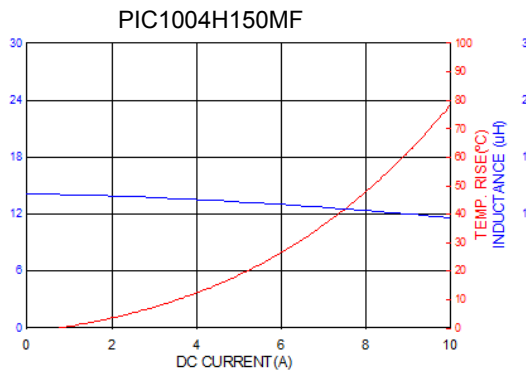
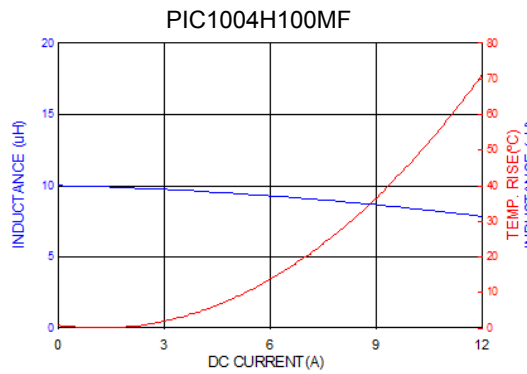
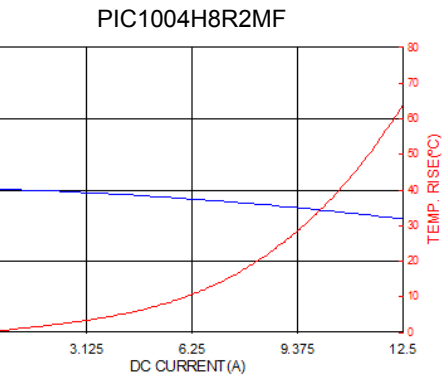
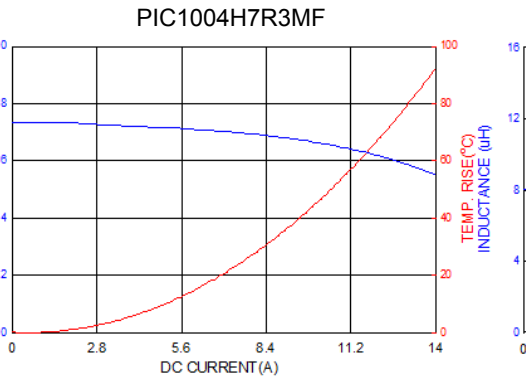
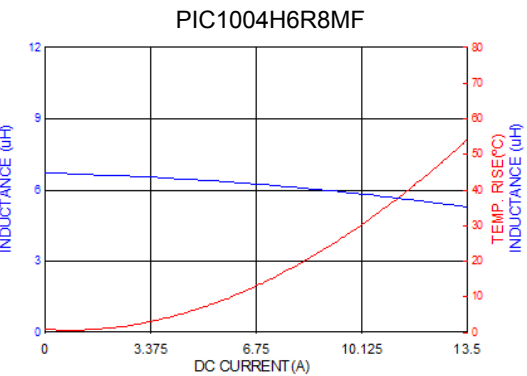
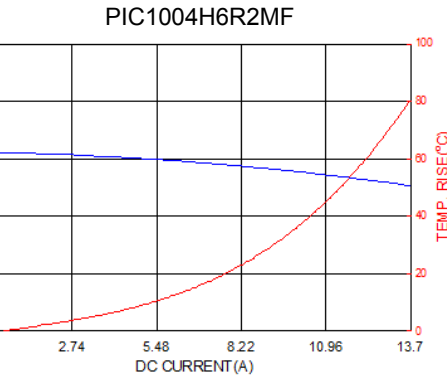
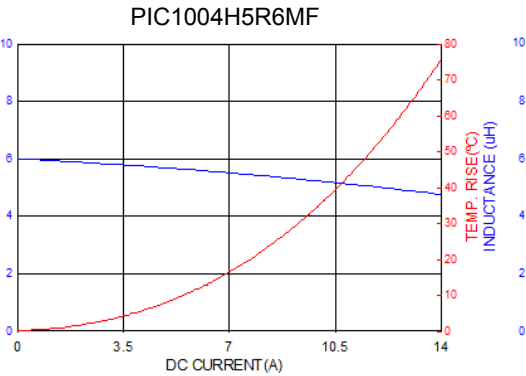
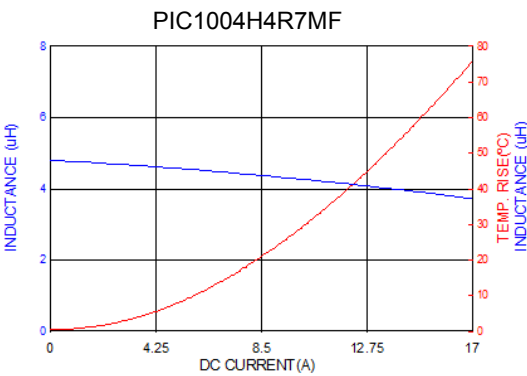
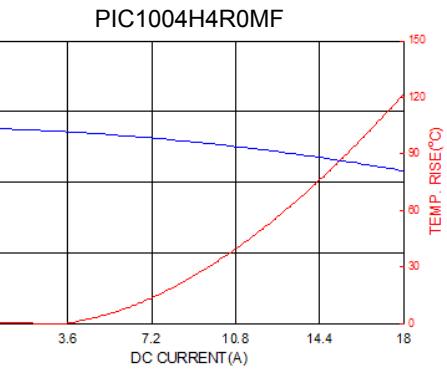
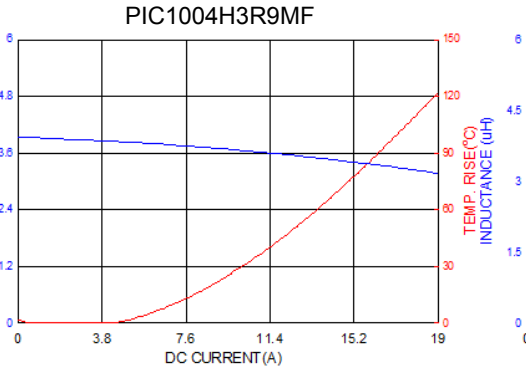
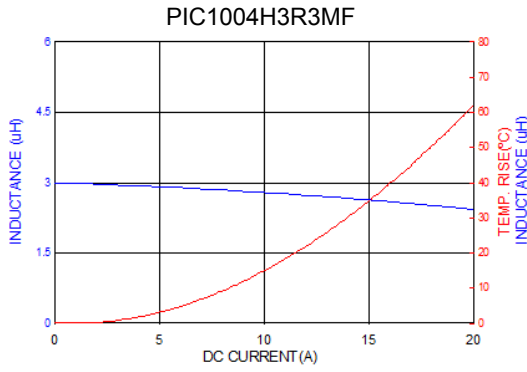

NOTE: Specifications subject to change without notice. Please check our website for latest information.



PIC1004H220MF

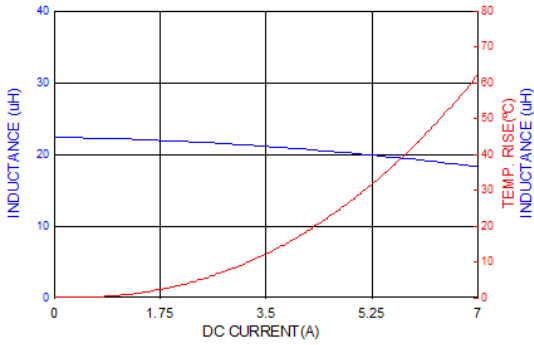

PIC1004H270MF

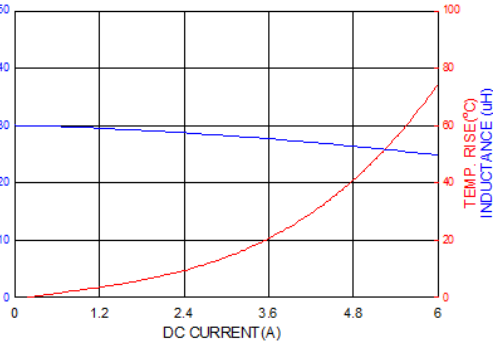

PIC1004H330MF

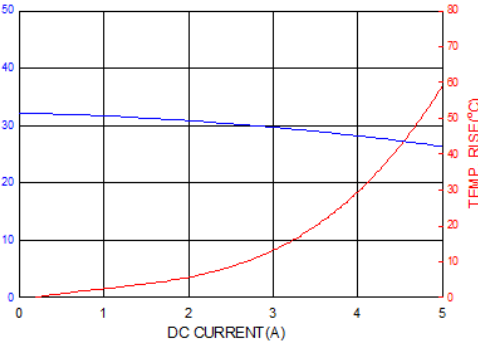

PIC1004H470MF

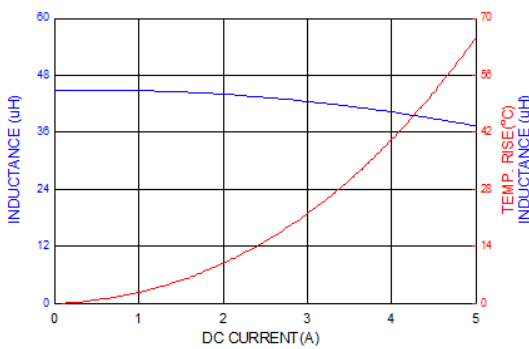

PIC1004H680MF

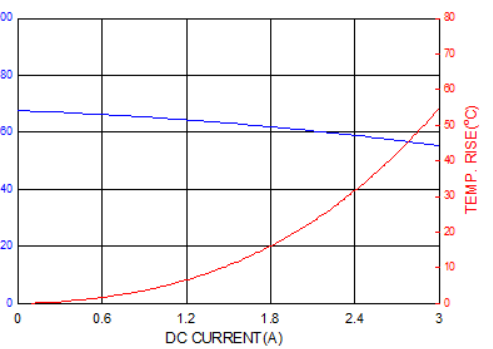

## 8. Soldering:

Mildly activated rosin fluxes are preferred. The minimum amount of solder can lead to damage from the stresses caused by the difference in coefficients of expansion between solder, chip and substrate. Our terminations are suitable for all re-flow soldering systems. If hand soldering cannot be avoided, the preferred technique is the utilization of hot air.

### 8-1 Solder Re-flow:

Recommended temperature profiles for re-flow soldering in Figure 1.

### 8-2 Soldering Iron (Figure 2):

Products attachment with soldering iron is discouraged due to the inherent process control limitations

In the event that a soldering iron must be employed the following precautions are recommended.

Notes:

- a) Preheat circuit and products to 150°C.
- b) 355°C tip temperature (Max.)
- c) Never contact the ceramic with the iron tip
- d) 1.0mm tip diameter (Max.)
- e) Use a 20 watt soldering iron with tip diameter of 1.0mm
- f) Limit soldering time to 4~5 sec

NOTE: Specifications subject to change without notice. Please check our website for latest information.



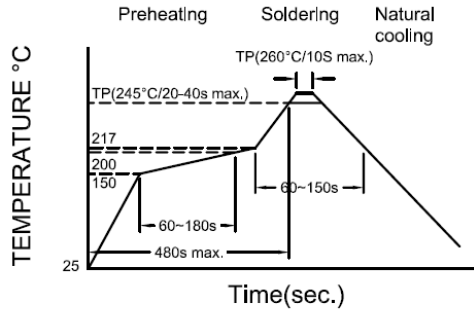

Reflow times: 3 times max

Fig.1

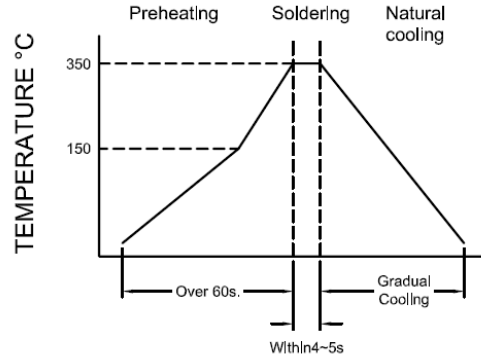

Iron Soldering times: 1 times max

Fig.2

9. Packaging Information:

9-1 Reel Dimension:

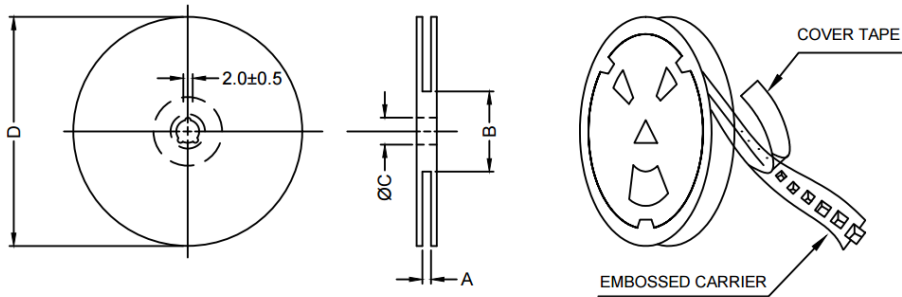

Type	A(mm)	B(mm)	C(mm)	D(mm)
13"x24mm	24.4+2/-0	100±2	13.5+0.5/-0.2	330

9-2 Tape Dimension:

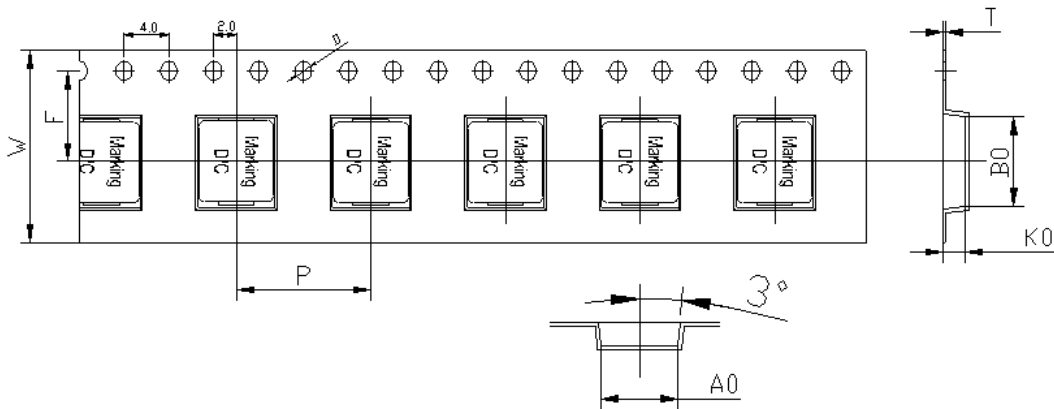

Series	Size	Bo(mm)	Ao(mm)	Ko(mm)	P(mm)	W(mm)	F(mm)	T(mm)	D(mm)
PIC	1004	11.6±0.1	10.4±0.1	4.5±0.1	16.0±0.1	24±0.3	11.5±0.1	0.35±0.05	1.5±0.1

NOTE: Specifications subject to change without notice. Please check our website for latest information.



### 9-3 Packaging Quantity:

PIC	1004
Chip / Reel	500
Inner box	1000
Carton	4000

### 9-4 Tearing Off Force:

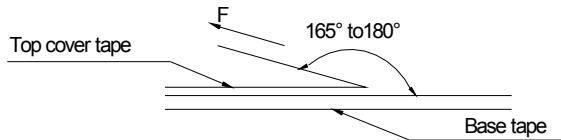

The force for tearing off cover tape is 10 to 130 grams in the arrow direction under the following conditions.

Room Temp. (°C)	Room Humidity (%)	Room atm (hPa)	Tearing Speed mm/min
5~35	45~85	860~1060	300

## Application Notice:

#### 1. Storage Conditions:

To maintain the solderability of terminal electrodes:

- a) Recommended products should be used within 12 months from the time of delivery.
- b) The packaging material should be kept where no chlorine or sulfur exists in the air.

#### 2. Transportation:

- a) Products should be handled with care to avoid damage or contamination from perspiration and skin oils.
- b) Vacuum pick up is strongly recommended for individual components.
- c) Bulk handling should ensure that abrasion and mechanical shock are minimized.

NOTE: Specifications subject to change without notice. Please check our website for latest information.