

1. Part No. Expression:

**SCT50046R3KMP11**

(a) (b) (c) (d) (e)

- a) Series Code
- b) Dimension Code
- c) Inductance Code
- d) Tolerance Code
- e) Qi Design Type Code

2. Configuration & Dimensions: (Unit:- mm)

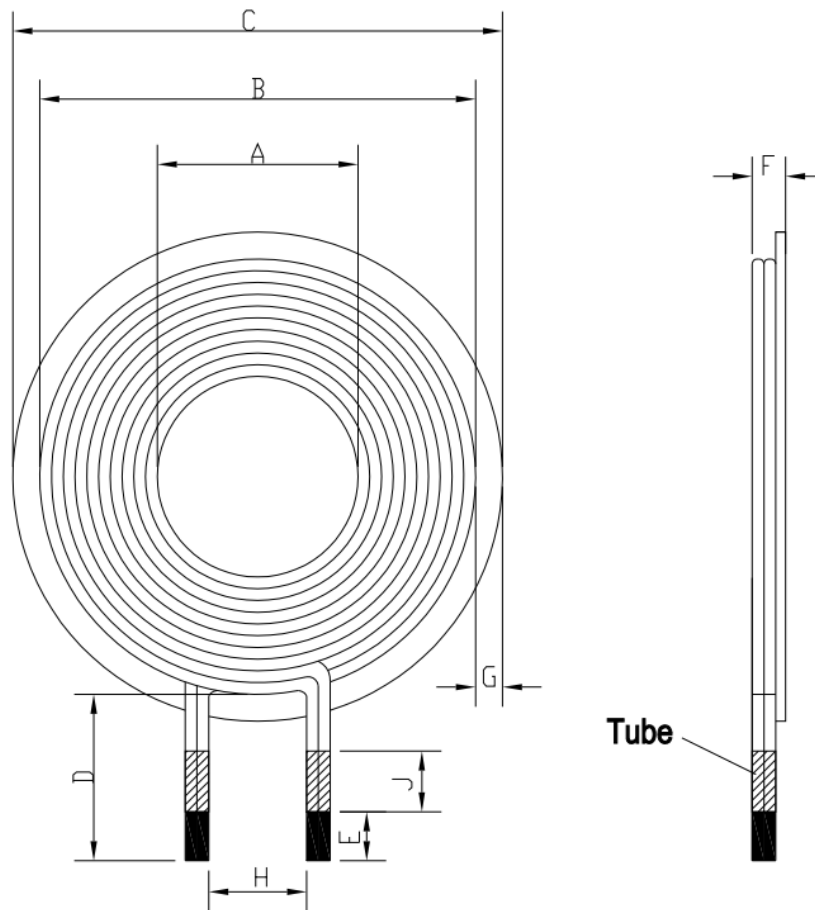

A	B	C	D	E	F	G	H	J
20.5±0.5	44.0±1.5	50.0±0.5	17.0±2.0	5.0±2.0	4.0 Max	2.0 Min	10.0 Ref	8.0 Ref

NOTE: Specifications subject to change without notice. Please check our website for latest information.



### 3. Schematic:



### 4. Electrical Characteristics:

Inductance (uH)	Test Frequency (Hz)	DCR (mΩ)	I <sub>rms</sub> (mA)
6.3±10%	1V/100K	25 Max.	10000 Max.

### 5. General Specifications:

- a) Operating Temp: -40°C ~ +85°C
- b) Storage Temp: -40°C ~ +85°C (packaging)
- c) I<sub>rms</sub>: Based on temp. rise up to 40°C Max.
- d) Power Rating: 15W
- e) Compatible to Qi standard MP-A11 design.

### 6. Material List:

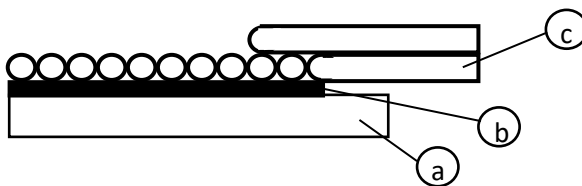

- (a) Ferrite Sheet (MnZn)
- (b) Adhesive
- (c) Wire

NOTE: Specifications subject to change without notice. Please check our website for latest information.