

1. Part No. Expression:

**W Q 3 F 2 0 1 - R C - 1 0**

(a) (b) (c) (d) (e)(f) (g)

- (a) Series Code
- (b) Dimension Code
- (c) Material Code
- (d) Inductance Code
- (e) Packaging Code
- (f) Current Rating Code
- (g) Internal Controlled Number

2. Configuration & Dimensions:

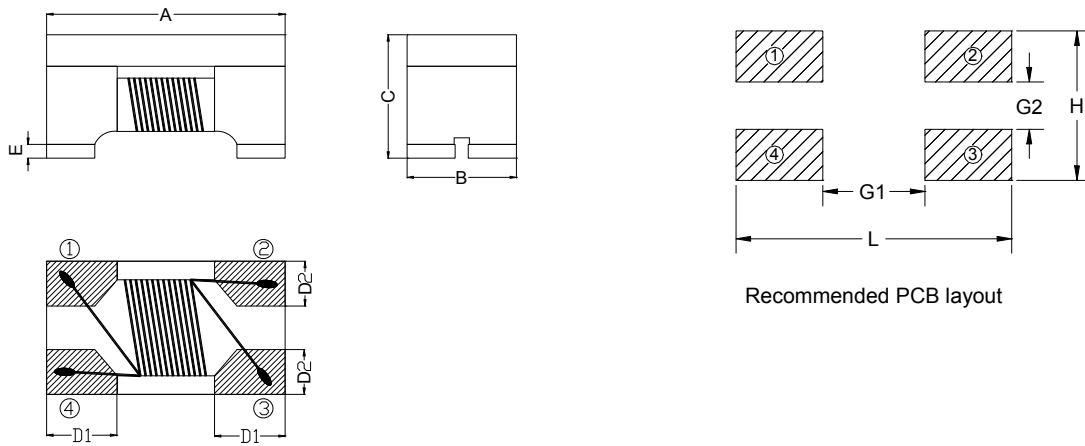

Unit: mm

A	B	C	D1	D2	E	L	H	G1	G2
2.0±0.2	1.2±0.2	1.2±0.2	0.55±0.1	0.46±0.1	0.15±0.1	2.60 Ref.	1.25 Ref.	1.10 Ref.	0.45 Ref.

3. Schematic:

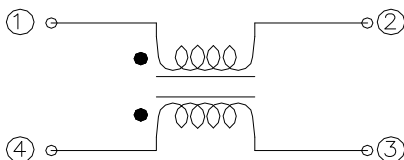

NOTE: Specifications subject to change without notice. Please check our website for latest information.

#### 4. Material List:

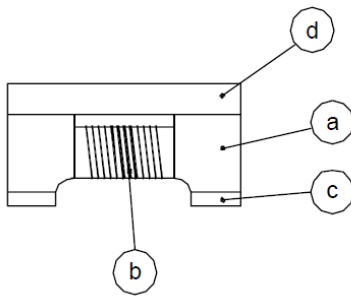

- (a) Core
- (b) Wire
- (c) Terminal
- (d) Upper Plate

#### 5. General Specification:

- (a) Reliability Test for this part meets AEC-Q200 standard.
- (b) Operating Temp. : -55°C to +125°C(Including self - temperature rise).
- (c) Storage Temp. : -55°C to +125°C (on board).
- (d) Humidity Range: 85 ± 3% RH.
- (e) Storage Condition (Component in its packaging)
  - i) Temperature: Less than 40°C
  - ii) Humidity : 60% RH

#### 6. Electrical Characteristics:

Part Number	Common mode Impedance (Ω) ±25%	Test Frequency (MHz)	DCR (Ω) Max.	Rated Current (mA) Max.	Rated Volt (Vdc) Max.	Withstand Volt (Vdc) Max.	IR (Ω) Min.
WQ3F670-RD-10	67	100	0.25	400	50	125	10M
WQ3F900-RD-10	90	100	0.30	400	50	125	10M
WQ3F121-RD-10	120	100	0.30	400	50	125	10M
WQ3F161-RC-10	160	100	0.35	350	50	125	10M
WQ3F181-RC-10	180	100	0.35	350	50	125	10M
WQ3F201-RC-10	200	100	0.40	300	50	125	10M
WQ3F221-RC-10	220	100	0.40	300	50	125	10M
WQ3F261-RC-10	260	100	0.40	300	50	125	10M
WQ3F361-RC-10	360	100	0.50	300	50	125	10M

NOTE: Specifications subject to change without notice. Please check our website for latest information.

7. Characteristics Curves:

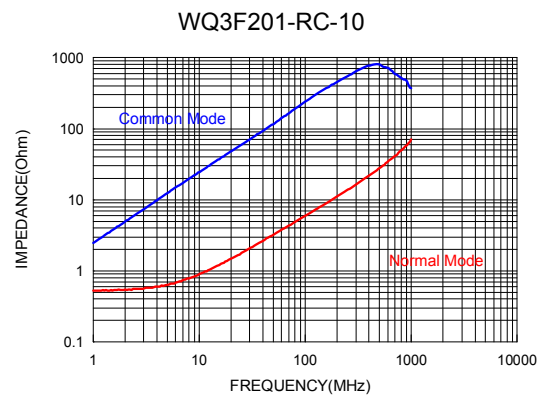
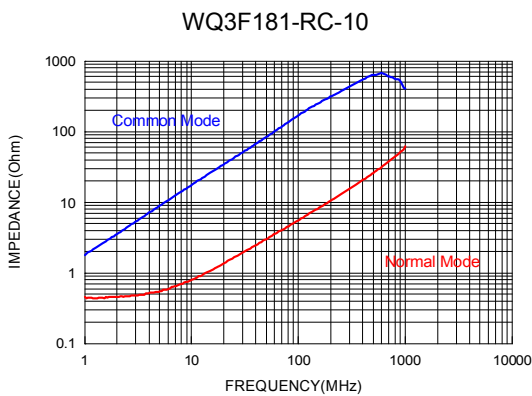
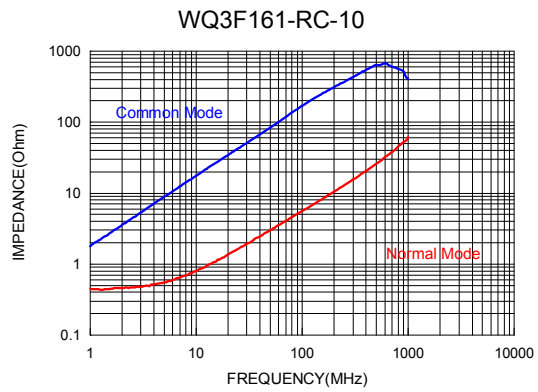
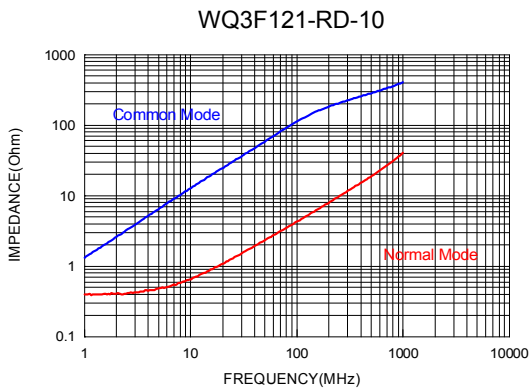
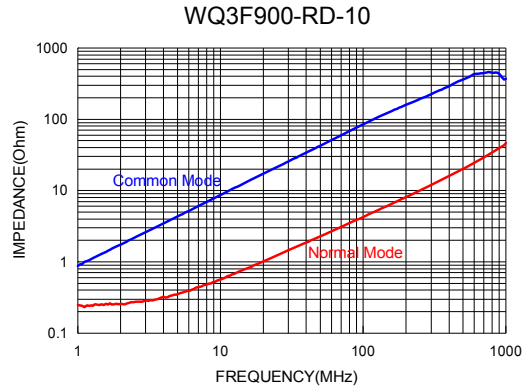
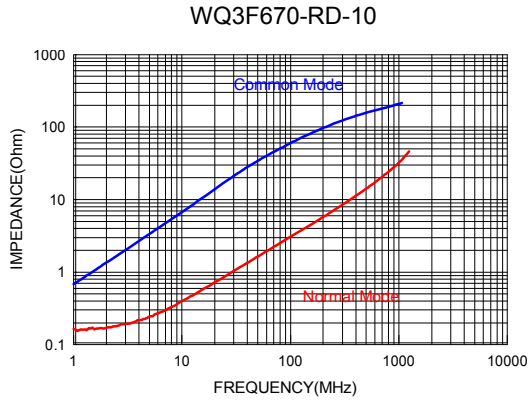

NOTE: Specifications subject to change without notice. Please check our website for latest information.



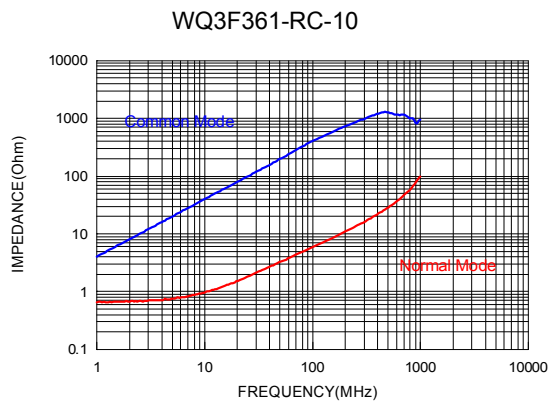
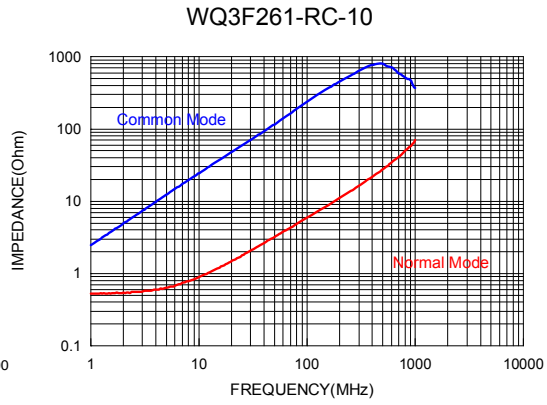
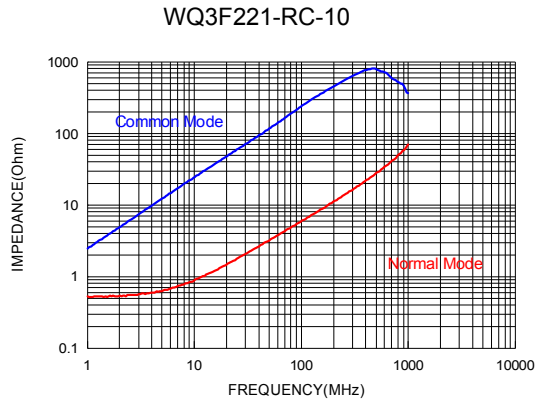

NOTE: Specifications subject to change without notice. Please check our website for latest information.



## 8. Soldering:

Mildly activated rosin fluxes are preferred. Our terminations are suitable for all re-flow soldering systems. If hand soldering cannot be avoided, the preferred technique is the utilization of hot air soldering tools.

### 8-1 Solder Re-flow

Recommended temperature profiles for re-flow soldering in Figure 1.

### 8-2 Soldering Iron (Figure 2)

Products attachment with soldering iron is discouraged due to the inherent process control limitations. In the event that a soldering iron must be employed the following precautions are recommended.

Note :

- Preheat circuit and products to 150°C.
- 355°C tip temperature (Max.)
- Never contact the ceramic with the iron tip
- 1.0mm tip diameter (Max.)
- Use a 20 watt soldering iron with tip diameter of 1.0mm
- Limit soldering time to 4~5 sec.

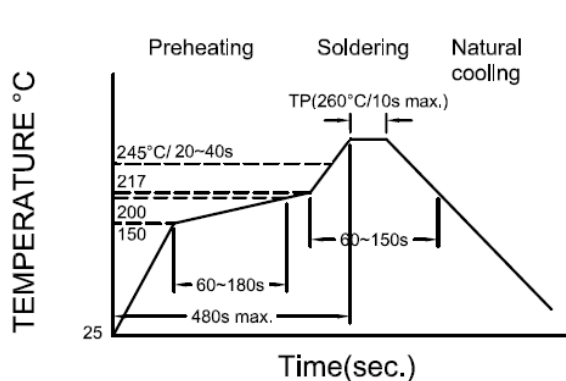

Figure 1. : Re-flow Soldering time  
3 times Max.

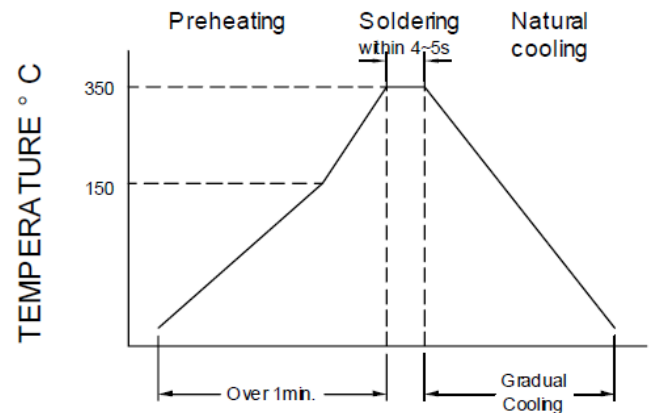
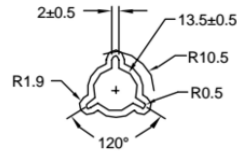
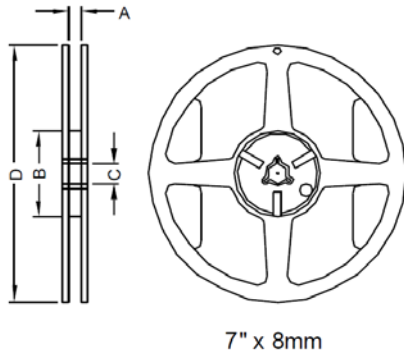

Figure 2. : Iron Soldering time  
1 times Max.

NOTE: Specifications subject to change without notice. Please check our website for latest information.

9. Packaging Information:

9-1 Reel Dimension



Type	A(mm)	B(mm)	C(mm)	D(mm)
7"x8mm	9.0 ± 0.5	60.0 ± 2.0	13.5 ± 0.5	178.0 ± 2.0

9-2 Tape Dimension

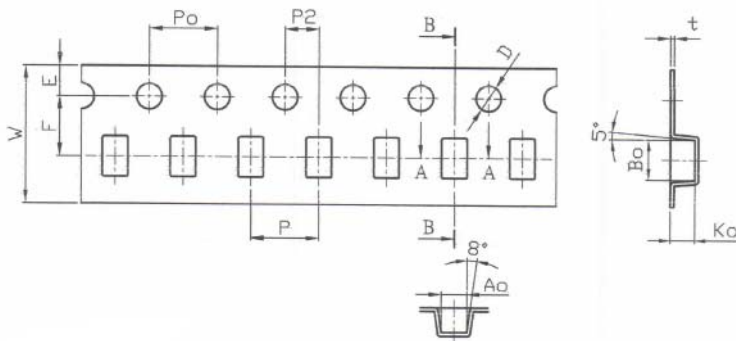

Size	P(mm)	Po(mm)	P2(mm)	Bo(mm)	Ao(mm)	Ko(mm)
	4.00±0.10	4.00±0.10	2.00±0.05	2.35±0.10	1.50±0.10	1.45±0.10
WQ3F	D(mm)	E(mm)	F(mm)	W(mm)	t(mm)	
	1.50+0.10/-0	1.75±0.10	3.50±0.05	8.00±0.10	0.28±0.05	

NOTE: Specifications subject to change without notice. Please check our website for latest information.

9-3 Packaging Quantity

Chip Size	WQ3F
Chip/Reel	2,000
Inner Box	10,000
Middle Box	50,000
Carton	100,000

10-4 Tearing Off Force

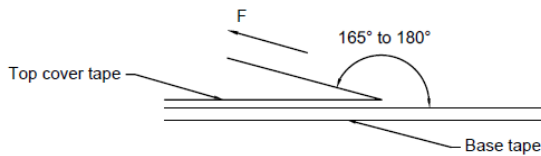

The force for tearing off cover tape is 15 to 80 grams in the arrow direction under the following conditions.

Room Temp. (°C)	Room Humidity (%)	Room atm (hPa)	Tearing Speed mm/min
5~35	45~85	860~1060	300

**Application Notice:**

1. Storage Conditions:

To maintain the solderability of terminal electrodes:

- a) Recommended products should be used within 12 months from the time of delivery.
- b) The packaging material should be kept where no chlorine or sulfur exists in the air.

2. Transportation:

- a) Products should be handled with care to avoid damage or contamination from perspiration and skin oils.
- b) Vacuum pick up is strongly recommended for individual components.
- c) Bulk handling should ensure that abrasion and mechanical shock are minimized.

NOTE: Specifications subject to change without notice. Please check our website for latest information.

