

1. Part No. Expression

PIFQ1508A2R0M0

(a) (b) (c) (d) (e) (f)

- | | |
|--------------------|---------------------|
| (a) Series Code | (d) Inductance Code |
| (b) Dimension Code | (e) Tolerance Code |
| (c) Material Code | (f) Special Code |

2. Configuration & Dimensions (Unit: mm)

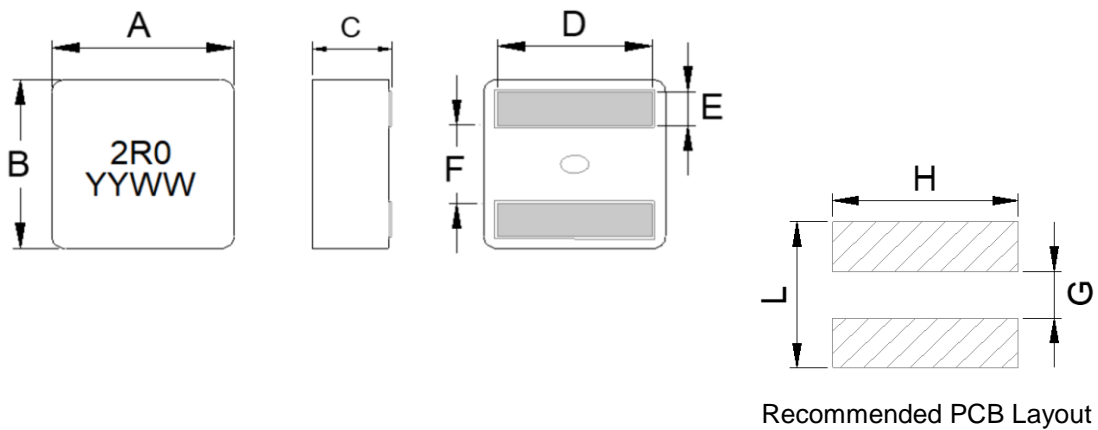

- Note:
1. The above PCB layout reference only.
 2. Recommend solder paste thickness at 0.15 mm and above.
 3. Marking: Top= Inductance Code, Bottom=YYWW (Year/World week)

| A | B | C | D | E |
|----------|----------|---------|----------|---------|
| 17.5±0.3 | 16.5±0.3 | 7.7±0.3 | 13.2±0.5 | 3.2±0.2 |
| F | L | G | H | - |
| 7.0±0.3 | 15.0 Ref | 6.0 Ref | 15.0 Ref | - |

NOTE: Specifications subject to change without notice. Please check our website for latest information.

3. Material List

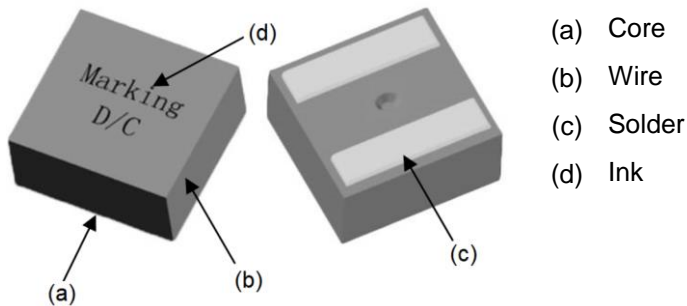

4. General Specifications

- (a) Reliability test for this part meets AEC-Q200 standard.
- (b) Operating Temp.: -55°C to +155°C (including self-temperature rise)
- (c) Storage Temp.: -55°C to +155°C (on board)
- (d) All test data referenced to 25°C ambient.
- (e) Heat Rated Current (Irms) will cause the coil temperature rise approximately ΔT of 20°C & 40°C.
- (f) Saturation Current (Isat) will cause inductance L0 to drop approximately 30%.
- (g) Rated Current: The lower value of Isat and Irms.
- (h) Part Temperature (Ambient + Temp. Rise): Should not exceed 155°C under worst case operating conditions.
- (i) Rated operating voltage (across inductor) 40V Ref.
- (j) Storage Condition (Component in its packaging)
 - i) Temperature: Less than 40°C
 - ii) Humidity: Less than 60% RH

NOTE: Specifications subject to change without notice. Please check our website for latest information.

5. Electrical Characteristics

| Part Number | Inductance (uH) @0A ±20% | Irms(A) | | Isat(A) | | DCR(mΩ) | |
|----------------|--------------------------------|---------------|---------------|---------|------|---------|------|
| | | @20°C rise | @40°C rise | Typ | Max | Typ | Max |
| PIFQ1508A2R0MO | 2.00 | 29.5 | 40.0 | 57.0 | 52.0 | 1.92 | 2.21 |
| PIFQ1508A2R2MO | 2.20 | 28.0 | 37.0 | 55.0 | 49.0 | 2.15 | 2.48 |
| PIFQ1508A3R0MO | 3.00 | 26.0 | 34.5 | 46.0 | 41.0 | 2.5 | 3.0 |
| PIFQ1508A4R2MO | 4.20 | 20.5 | 27.0 | 38.0 | 33.0 | 3.9 | 4.68 |
| PIFQ1508A4R7MO | 4.70 | 20.0 | 26.5 | 37.0 | 32.0 | 4.3 | 5.16 |
| PIFQ1508A5R3MO | 5.30 | 19.5 | 26.0 | 35.0 | 31.0 | 4.45 | 5.34 |
| PIFQ1508A6R2MO | 6.20 | 17.0 | 23.0 | 34.0 | 31.0 | 5.4 | 6.5 |
| PIFQ1508A7R2MO | 7.20 | 15.0 | 21.0 | 32.0 | 29.0 | 6.0 | 7.2 |
| PIFQ1508A8R2MO | 8.20 | 13.0 | 19.0 | 28.0 | 25.0 | 6.6 | 7.92 |
| PIFQ1508A100MO | 10.0 | 11.0 | 16.0 | 24.0 | 21.0 | 8.0 | 9.6 |
| PIFQ1508A150MO | 15.0 | 10.0 | 13.0 | 21.0 | 18.0 | 12.5 | 15.0 |
| PIFQ1508A220MO | 22.0 | 9.0 | 12.0 | 19.0 | 16.0 | 19.3 | 23.2 |

Test frequency: 0.1V/100kHz

NOTE: Specifications subject to change without notice. Please check our website for latest information.

6. Characteristics Curve

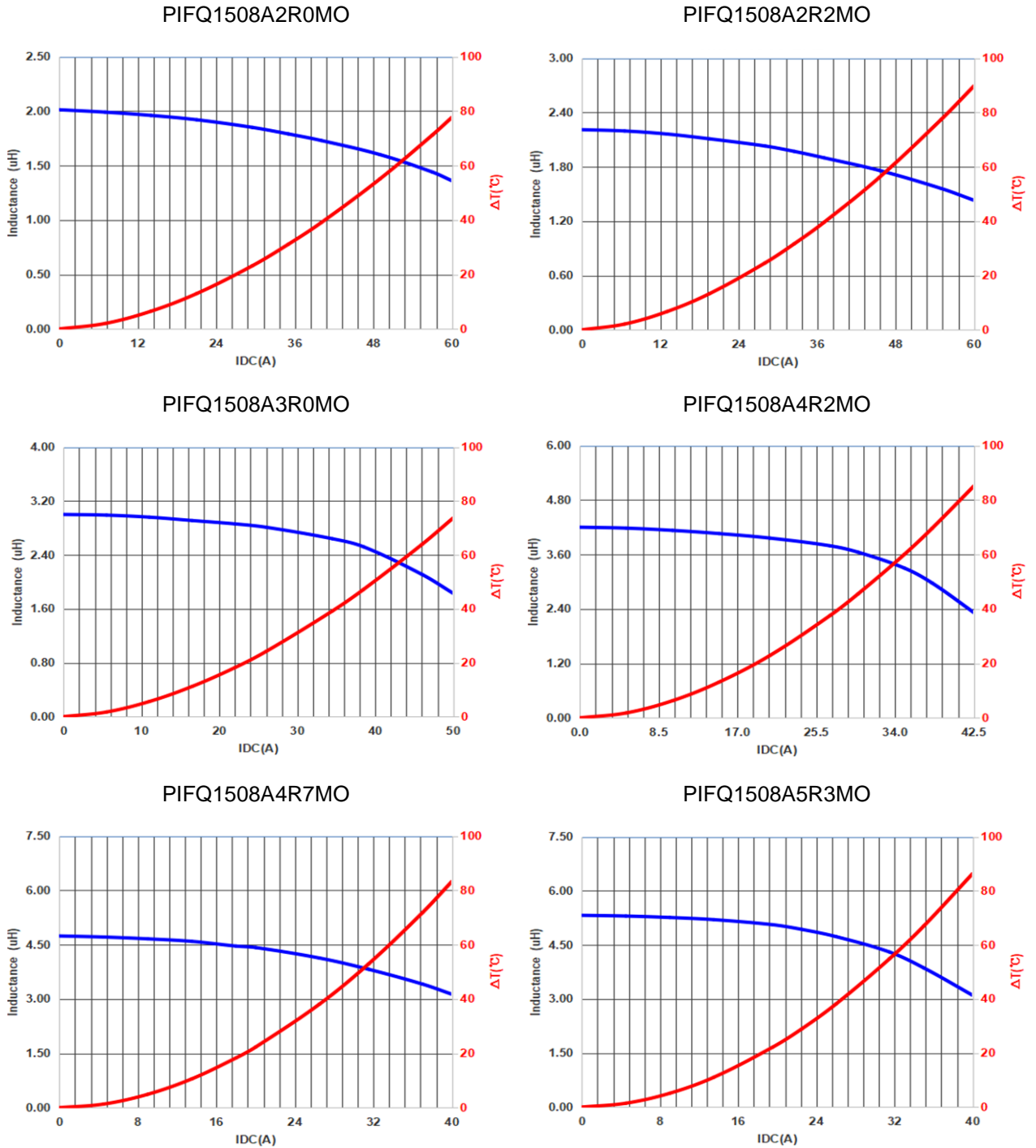

NOTE: Specifications subject to change without notice. Please check our website for latest information.

PIFQ1508A6R2MO

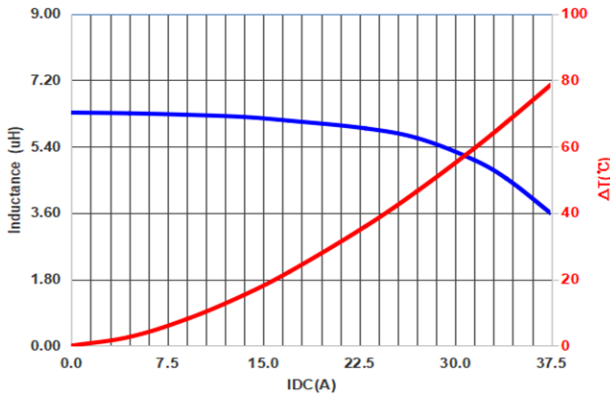

PIFQ1508A7R2MO

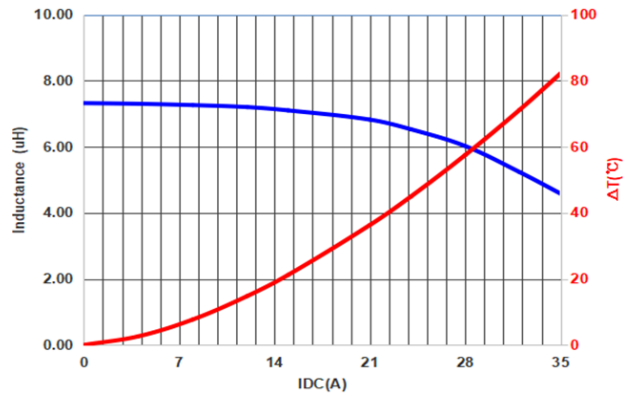

PIFQ1508A8R2MO

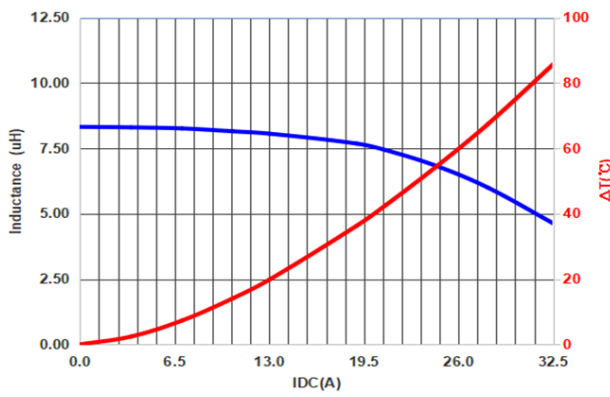

PIFQ1508A100MO

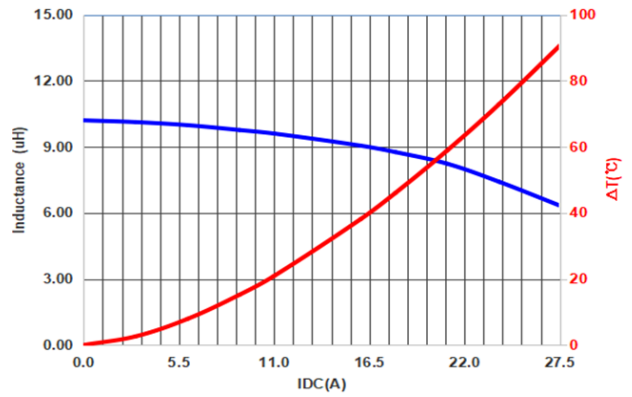

PIFQ1508A150MO

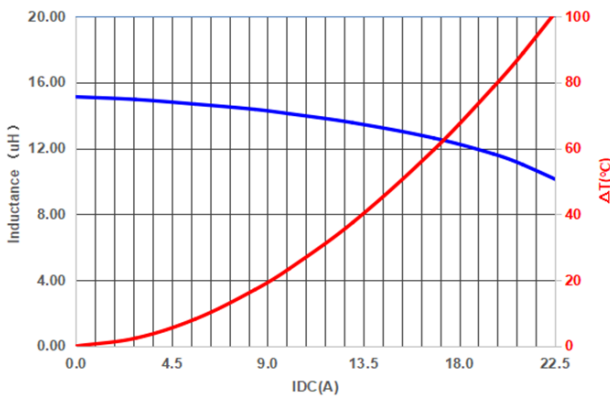

PIFQ1508A220MO

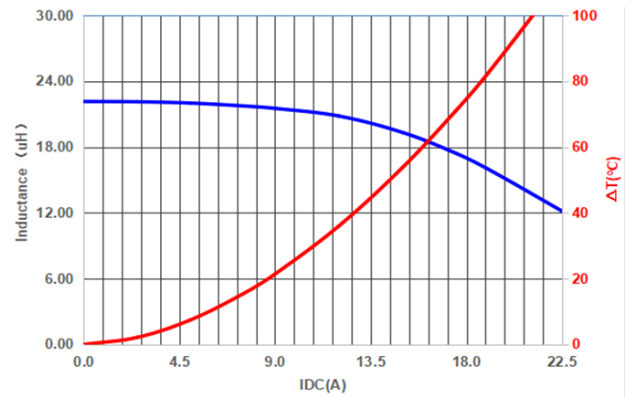

NOTE: Specifications subject to change without notice. Please check our website for latest information.

7. Soldering Specification

Mildly activated rosin fluxes are preferred. Our terminations are suitable for re-flow soldering systems. If hand soldering cannot be avoided, the preferred technique is the utilization of hot air soldering tools.

7-1. IR Soldering Reflow

Recommended temperature profiles for lead free re-flow soldering in Figure 1, Table 1.1 & 1.2 (J-STD-020E).

7-2. Iron Reflow

Products attachment with a soldering iron is discouraged due to the inherent process control limitations. In the event that a soldering iron must be employed the following precautions are recommended (Figure 2).

Note:

- (a) Preheat circuit and products to 150°C.
- (b) 355°C tip temperature (Max.)
- (c) Never contact the ceramic with the iron tip
- (d) 1.0mm tip diameter (Max.)
- (e) Use a 20 watt soldering iron with tip diameter of 1.0mm
- (f) Limit soldering time to 4~5 sec.

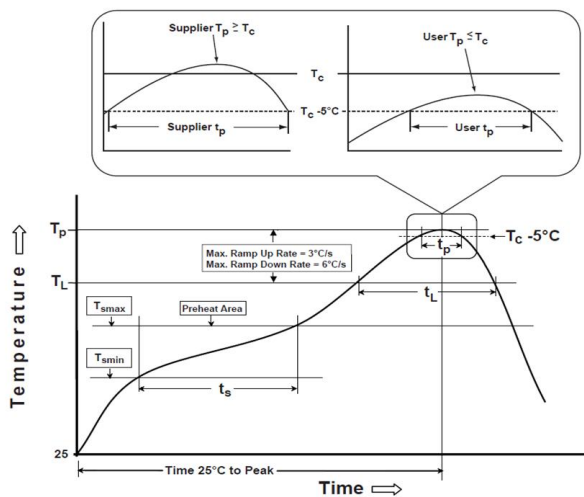

Reflow times: 3 times Max

Figure 1: IR Soldering Reflow

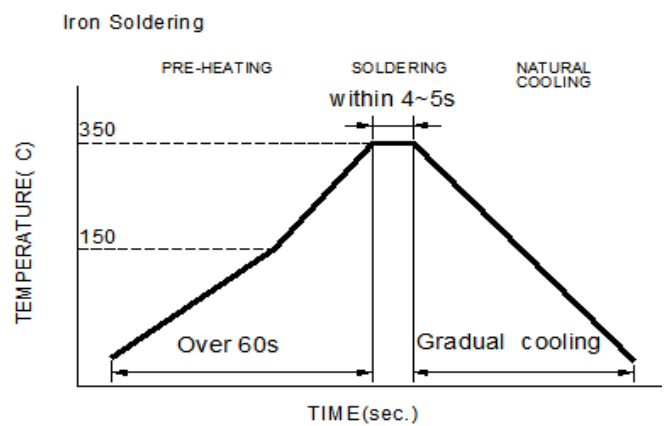

Iron Soldering times: 1 times max.

Soldering iron method: 350±5°C Max

Figure 2: Iron soldering temperature profiles

NOTE: Specifications subject to change without notice. Please check our website for latest information.

Table (1.1) Reflow Profiles

| | |
|--|------------------|
| Profile Type: | Pb-Free Assembly |
| Preheat | |
| -Temperature Min (T_{smin}) | 150°C |
| -Temperature Max (T_{smax}) | 200°C |
| -Time (t_s) from (T_{smin} to T_{smax}) | 60-120seconds |
| Ramp-up rate (T_L to T_p) | 3°C /second max. |
| Liquids temperature (T_L) | 217°C |
| Time (t_L) maintained above T_L | 60-150 seconds |
| Classification temperature (T_c) | See Table (1.2) |
| Time (t_p) at $T_c - 5^\circ\text{C}$ (T_p should be equal to or less than T_c .) | * < 30 seconds |
| Ramp-down rate (T_p to T_L) | 6°C /second max. |
| Time 25°C to peak temperature | 8 minutes max. |

T_p: maximum peak package body temperature, **T_c**: the classification temperature.

For user (customer) **T_p** should be equal to or less than **T_c**.

*Tolerance for peak profile temperature (T_p) is defined as a supplier minimum and a user maximum.

Table (1.2) Package Thickness/Volume and Classification Temperature (T_c)

| | Package Thickness | Volume mm ³ <350 | Volume mm ³ 350-2000 | Volume mm ³ >2000 |
|------------------|-------------------|-----------------------------|---------------------------------|------------------------------|
| PB-Free Assembly | <1.6mm | 260°C | 260°C | 260°C |
| | 1.6-2.5mm | 260°C | 250°C | 245°C |
| | ≥2.5mm | 250°C | 245°C | 245°C |

Reflow is referred to standard IPC/JEDEC J-STD-020E.

NOTE: Specifications subject to change without notice. Please check our website for latest information.

8. Packaging Information

8-1. Reel Dimension (Unit: mm)

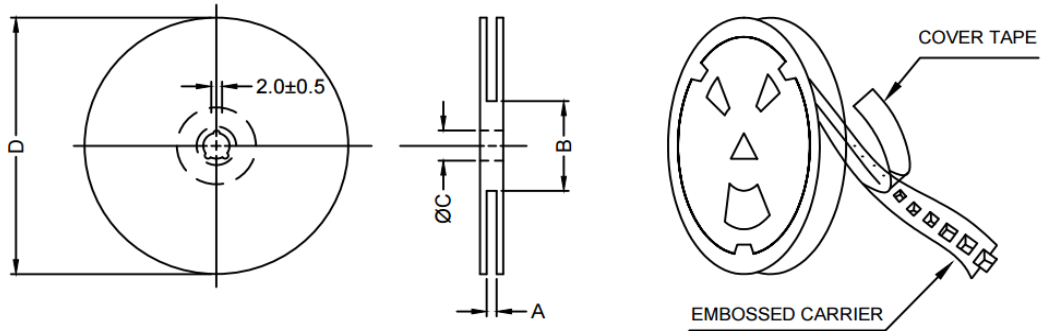

| Type | A | B | C | D |
|----------|---------------|-----------|---------------|-------|
| 13"x32mm | 32.4+2.0/-0.0 | 100.0±2.0 | 13.0+0.5/-0.2 | 330.0 |

8-2. Tape Dimension (Unit: mm)

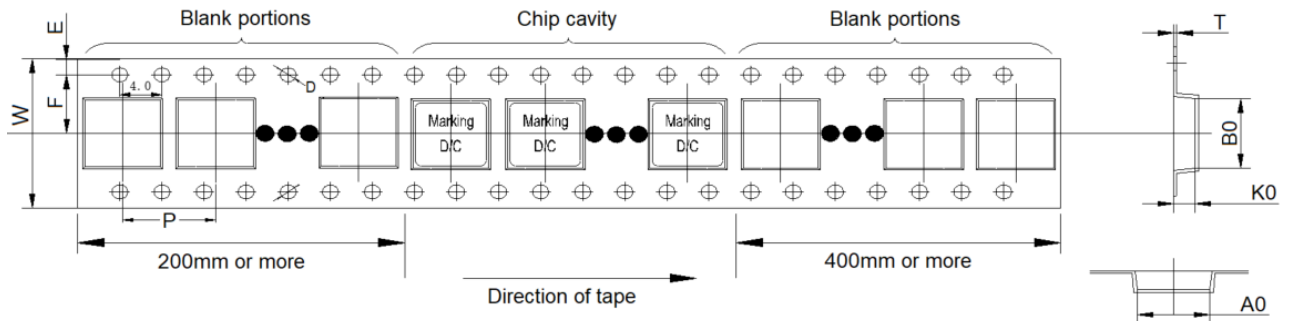

| | | | | |
|------------|------------|-----------|------------|------------|
| B0 | A0 | K0 | P | W |
| 17.00±0.10 | 18.00±0.10 | 8.50±0.10 | 24.00±0.10 | 32.00±0.30 |
| E | F | T | D | - |
| 1.75±0.10 | 14.20±0.10 | 0.50±0.05 | 1.50±0.10 | - |

NOTE: Specifications subject to change without notice. Please check our website for latest information.

8-3. Packaging Quantity (Unit: Pcs)

| | |
|------------|-----|
| Chip/ Reel | 200 |
|------------|-----|

8-4. Tearing Off Force

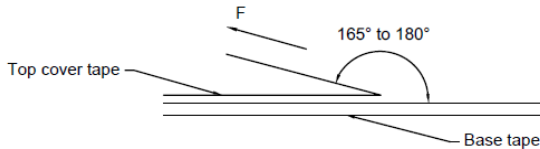

The force for tearing off cover tape is according to the follow table, in the arrow direction under the following conditions.

(Referenced ANSI/EIA-481-D-2008 of 4.11 standard)

| Room Temp. (°C) | Room Humidity (%) | Room atm (hPa) | Tearing Speed (mm/min) |
|-----------------|-------------------|----------------|------------------------|
| 5~35 | 45~85 | 860~1060 | 300±10 |

| Tape Size | 8 mm | 12 to 56 mm | 72 mm or Wider |
|---------------------------|--------|-------------|----------------|
| Tearing Off Force (grams) | 10~100 | 10~130 | 10~150 |

Application Notice

1. Storage Conditions

To maintain the solderability of terminal electrodes:

- (a) Recommended products should be used within 12 months from the time of delivery.
- (b) The packaging material should be kept where no chlorine or sulfur exists in the air.

2. Transportation

- (a) Products should be handled with care to avoid damage or contamination from perspiration and skin oils.
- (b) Vacuum pick up is strongly recommended for individual components.
- (c) Bulk handling should ensure that abrasion and mechanical shock are minimized.

NOTE: Specifications subject to change without notice. Please check our website for latest information.