

1. Part No. Expression

W Q J F A S 1 0 1 - R W - 1 0

(a) (b) (c) (d) (e) (f) (g) (h)

- (a) Series Code
- (b) Dimension Code
- (c) Material Code
- (d) Type Code
- (e) Impedance Code
- (f) Packaging Code
- (g) Current Code
- (h) Internal Code

2. Configuration & Dimensions (Unit: mm)

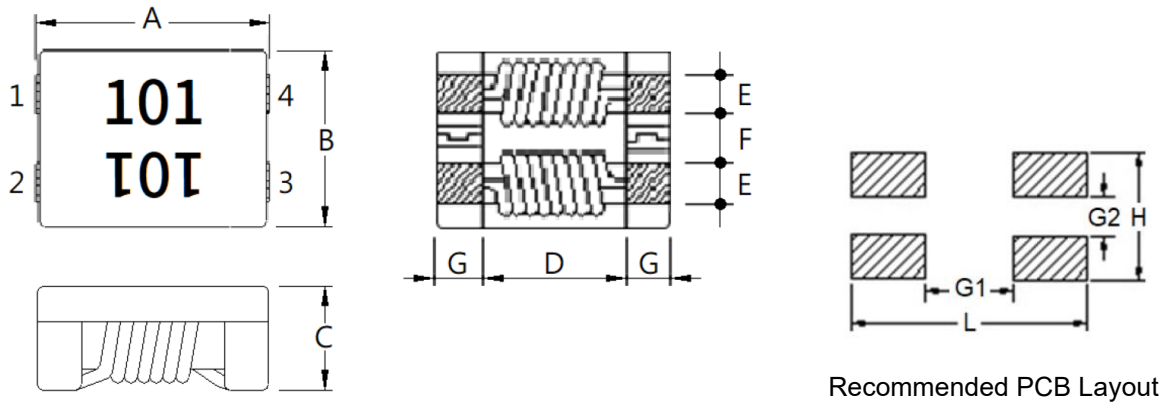

- Note: 1. The above PCB layout reference only.
 2. Laser Marking: Inductance Code

A	B	C	D	E	F
5.5±0.5	5.5±0.5	3.5 Max	3.3 Typ	1.2±0.5	1.9±0.5
G	L	H	G1	G2	-
1.1±0.5	5.9 Ref	4.3 Ref	3.3 Ref	1.9 Ref	-

NOTE: Specifications subject to change without notice. Please check our website for latest information.

3. Schematic

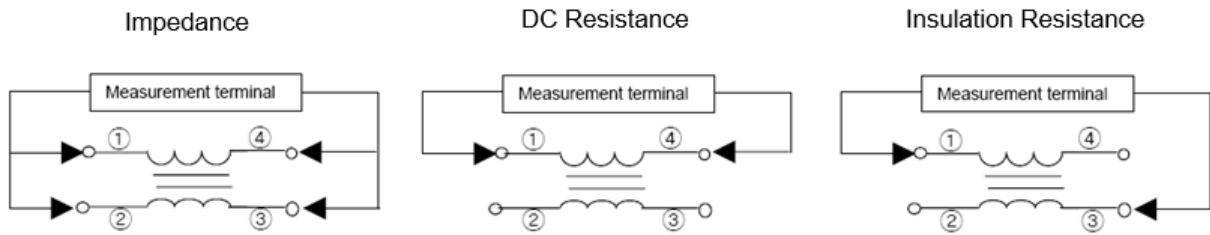

4. Material List

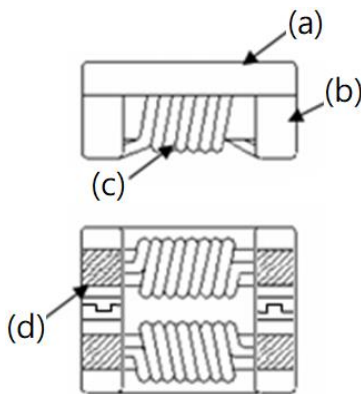

NO	Description
(a)	Upper Plate
(b)	Core
(c)	Wire
(d)	Termination

5. General Specifications

- (a) Reliability test for this part meets AEC-Q200 standard.
- (b) Operating Temp.: - 55°C to + 125°C (including self-temperature rise)
- (c) Storage Temp.: - 40°C to +125°C (on board)
- (d) All test data referenced to 25°C ambient.
- (e) Irms: Based on temperature rise ΔT 40°C Max at rated current $\geq 1A$
- (f) Storage Condition (Component in its packaging)
 - i) Temperature: Less than 40°C
 - ii) Humidity: Less than 60% RH

NOTE: Specifications subject to change without notice. Please check our website for latest information.

6. Electrical Characteristics

Part Number	Impedance (Ω)		Test Frequency (MHz)	DCR (mΩ) Max	Rated Current (A) Max	Rated Voltage (Vdc) Max	IR (MΩ) Min
	Min	Typ					
WQJFAS101-RW-10	100	140	100	6.0	8.5	80	10
WQJFAS301-RR-10	150	300	100	7.5	4.8	80	10
WQJFAS501-RQ-10	300	500	100	10.5	4.5	80	10
WQJFAS701-RP-10	500	700	100	13.0	3.8	80	10
WQJFAS102-RN-10	750	1000	100	20.0	3.0	80	10
WQJFAS142-RN-10	1000	1400	100	38.0	2.8	80	10

Note:

Measurement Board Data

Material: FR4

Board dimensions: 100 x 50 x 1.6t mm

Pattern dimensions: 45 x 30 mm (Double side board)

Pattern thickness: 50 μm

NOTE: Specifications subject to change without notice. Please check our website for latest information.

7. Characteristics Curve

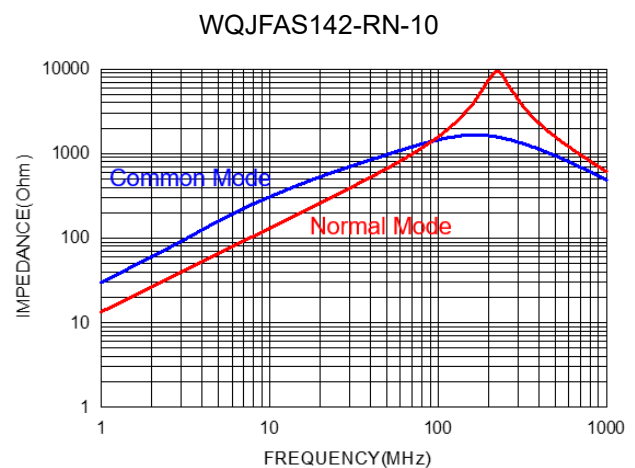
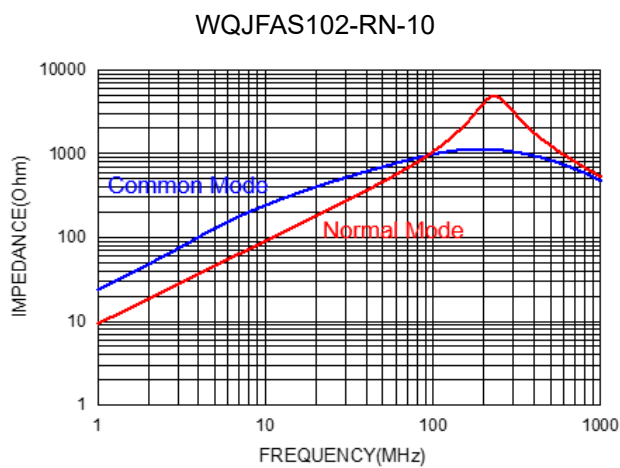
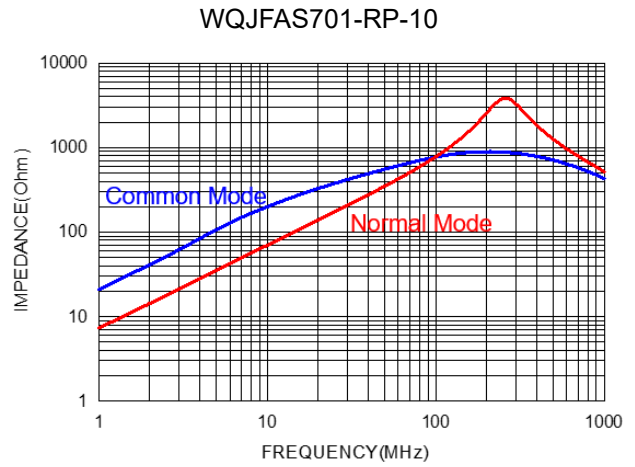
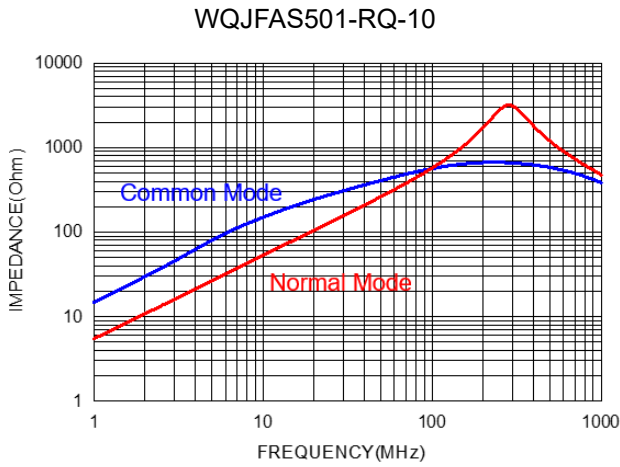
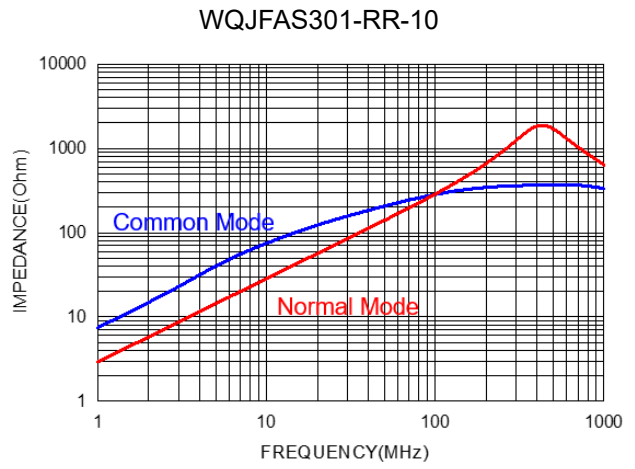
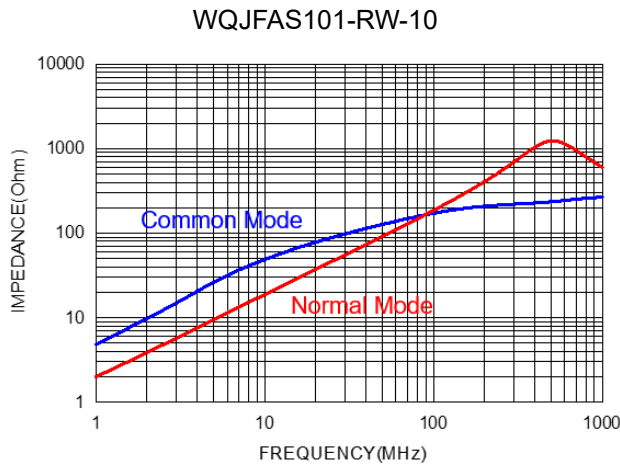

NOTE: Specifications subject to change without notice. Please check our website for latest information.

8. Soldering Specification

Mildly activated rosin fluxes are preferred. Our terminations are suitable for re-flow soldering systems. If hand soldering cannot be avoided, the preferred technique is the utilization of hot air soldering tools.

8-1. IR Soldering Reflow

Recommended temperature profiles for lead free re-flow soldering in Figure 1, Table 1.1 & 1.2 (J-STD-020F).

8-2. Iron Reflow

Products attachment with a soldering iron is discouraged due to the inherent process control limitations. In the event that a soldering iron must be employed the following precautions are recommended (Figure 2).

Note:

- (a) Preheat circuit and products to 150°C.
- (b) 350°C tip temperature (Max.)
- (c) Never contact the ceramic with the iron tip
- (d) 1.0mm tip diameter (Max.)
- (e) Use a 20 watt soldering iron with tip diameter of 1.0mm
- (f) Limit soldering time to 4~5 sec.

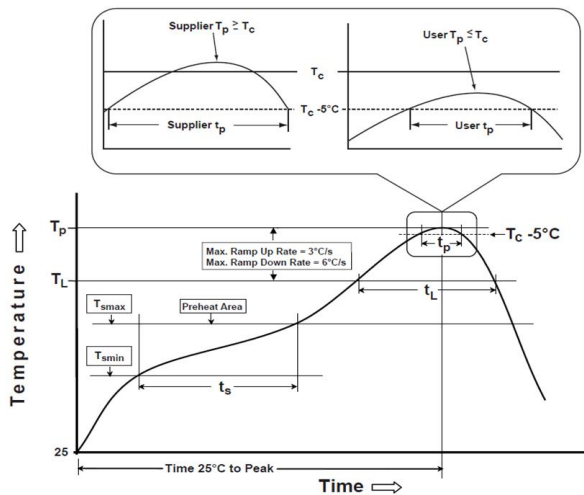

Reflow times: 3 times Max

Figure 1: IR Soldering Reflow

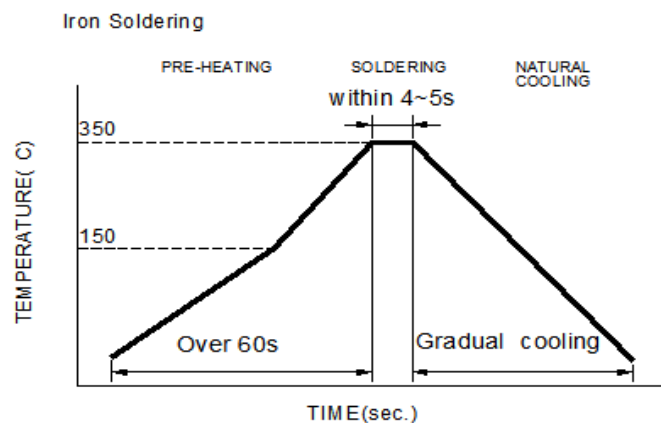

Iron Soldering times: 1 times max

Figure 2: Iron soldering temperature profiles

NOTE: Specifications subject to change without notice. Please check our website for latest information.

Table (1.1) Reflow Profiles

Profile Type:	Pb-Free Assembly
Preheat	
-Temperature Min (T_{smin})	150°C
-Temperature Max (T_{smax})	200°C
-Time (t_s) from (T_{smin} to T_{smax})	60-120seconds
Ramp-up rate (T_L to T_p)	3°C /second max.
Liquids temperature (T_L)	217°C
Time (t_L) maintained above T_L	60-150 seconds
Classification temperature (T_c)	See Table (1.2)
Time (t_p) at $T_c - 5^\circ\text{C}$ (T_p should be equal to or less than T_c .)	< 30 seconds
Ramp-down rate (T_p to T_L)	6°C /second max.
Time 25°C to peak temperature	8 minutes max.

T_p: maximum peak package body temperature, **T_c**: the classification temperature.

For user (customer) **T_p** should be equal to or less than **T_c**.

Table (1.2) Package Thickness/Volume and Classification Temperature (T_c)

	Package Thickness	Volume mm ³ <350	Volume mm ³ 350-2000	Volume mm ³ >2000
PB-Free Assembly	<1.6mm	260°C	260°C	260°C
	1.6-2.5mm	260°C	250°C	245°C
	≥2.5mm	250°C	245°C	245°C

Reflow is referred to standard IPC/JEDEC J-STD-020F.

8-3. Soldering Volume

Accordingly increasing the solder volume, the mechanical stress to product is also increased. Exceeding solder volume may cause the failure of mechanical or electrical performance. Solder shall be used not to be exceeded as shown in the Figure below.

Minimum fillet height = soldering thickness + 25% product height.

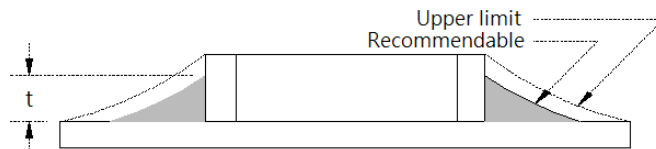

NOTE: Specifications subject to change without notice. Please check our website for latest information.

9. Packaging Information

9-1. Reel Dimension (Unit: mm)

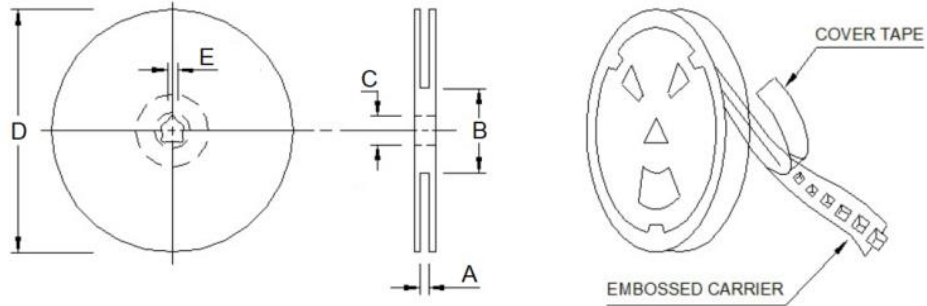

Type	A	B	C	D	E
13"x12mm	12.5 Ref	100.0 Ref	13.5 Ref	330.0 Ref	2.0 Ref

9-2. Tape Dimension (Unit: mm)

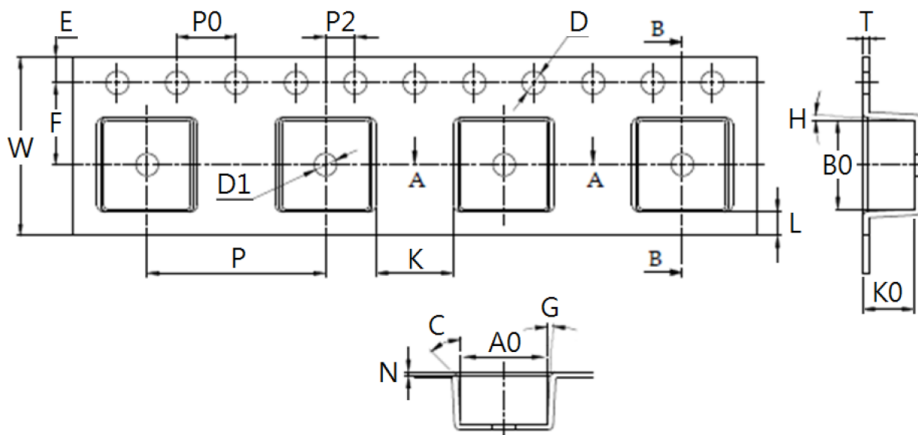

W	P	E	F	P0
12.0000±0.3000	12.0000±0.1000	1.7500±0.1000	5.5000±0.1000	4.0000±0.1000
P2	B0	A0	K0	D
2.0000±0.1000	5.9500±0.1000	5.8500±0.1000	3.5000±0.1000	1.5000+0.1000/-0.0000
D1	T	C	G	H
1.5000±0.1000	0.4000±0.0500	45°	3°	3°
K	L	N	-	-
5.2146	1.5916	0.3000	-	-

NOTE: Specifications subject to change without notice. Please check our website for latest information.

9-3. Packaging Quantity (Unit: Pcs)

Chip/ Reel	1,500
Inner Box	3,000
Carton	15,000

9-4. Tearing Off Force

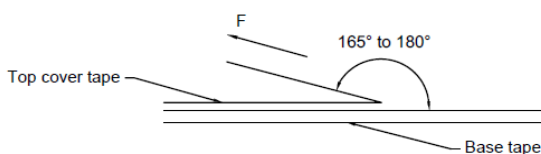

The force for tearing off cover tape is according to the follow table, in the arrow direction under the following conditions.

(Referenced ANSI/EIA-481-D-2008 of 4.11 standard)

Room Temp. (°C)	Room Humidity (%)	Room atm (hPa)	Tearing Speed (mm/min)
5~35	45~85	860~1060	300±10

Tape Size	8 mm	12 to 56 mm	72 mm or Wider
Tearing Off Force (grams)	10~100	10~130	10~150

Application Notice

1. Storage Conditions

To maintain the solderability of terminal electrodes:

- (a) Products meet IPC/JEDEC J-STD-020F standard-MSL, level 1.
- (b) Recommended products should be used within 12 months from the time of delivery.
- (c) The packaging material should be kept where no chlorine or sulfur exists in the air.

2. Transportation

- (a) Products should be handled with care to avoid damage or contamination from perspiration and skin oils.
- (b) Vacuum pick up is strongly recommended for individual components.
- (c) Bulk handling should ensure that abrasion and mechanical shock are minimized.

NOTE: Specifications subject to change without notice. Please check our website for latest information.