

1. Part No. Expression

PNS60451R0YW F

(a) (b) (c) (d) (e) (f)

- | | |
|---------------------|--------------------|
| (a) Series Code | (d) Tolerance Code |
| (b) Dimension Code | (e) Special Code |
| (c) Inductance Code | (f) Packaging Code |

2. Configuration & Dimensions (Unit: mm)

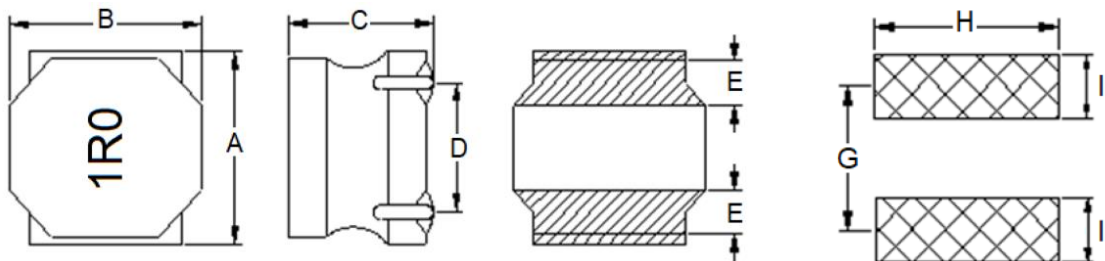

Recommended PCB Layout

- Note:
1. The above PCB layout reference only.
 2. Recommend solder paste thickness at 0.12 mm and above.
 3. Marking: Inductance Code

A	B	C	D	E	G	H	I
6.00±0.20	6.00±0.20	4.50 Max	4.00±0.20	1.35±0.20	4.70 Ref	5.70 Ref	1.60 Ref

3. Schematic

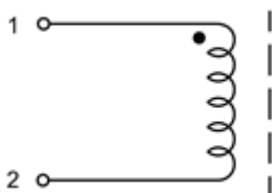

NOTE: Specifications subject to change without notice. Please check our website for latest information.

4. Material List

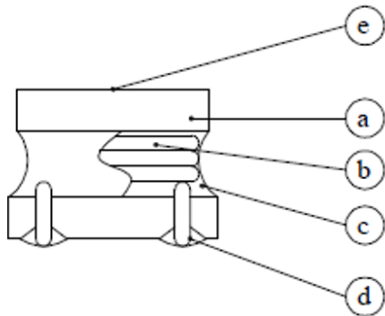

- (a) Core
- (b) Wire
- (c) Adhesive
- (d) Terminal
- (e) Ink

Void appearance tolerance limit & size of voids occurring to coating resin is specified below.

Exposed wire tolerance limit of coating resin part on product side.

Size of exposed wire occurring to coating resin is specified below:

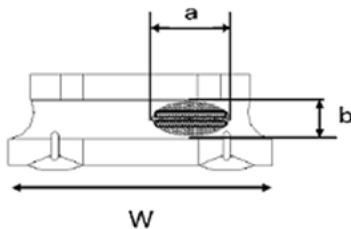

1. Width direction (dimension a) : Acceptable when $a \leq w/2$;

Nonconforming when $a > w/2$

2. Length direction (dimension b): Dimension b is not specified
3. The total area of exposed wire occurring to each side is not greater than 50% of coating resin area and is acceptable

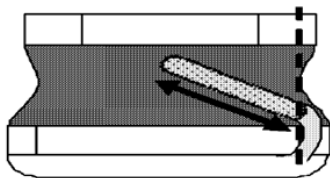

External appearance criterion for exposed wire.

Exposed end of the winding wire at the secondary side should be 2mm and below.

5. General Specifications

- (a) Operating Temp.: -40°C to +125°C (including self-temperature rise)
- (b) Storage Temp.: -40°C to +125°C (on board)
- (c) All test data referenced to 25°C ambient.
- (d) Heat Rated Current (Irms) will cause the coil temperature rise approximately ΔT of 40°C.
- (e) Saturation Current (Isat) will cause inductance L0 to drop 30% Max.
- (f) Rated Current: The lower value of Isat and Irms.
- (g) Storage Condition (Component in its packaging)
 - i) Temperature: Less than 40°C
 - ii) Humidity: Less than 60% RH

NOTE: Specifications subject to change without notice. Please check our website for latest information.

6. Electrical Characteristics

Part Number	Inductance (μH) @0A	Test Frequency	SRF (MHz) Typ	DCR (Ω) ±30%	Isat (A) Max	Irms (A) Max	Marking
PNS60451R0YWF	1.0	1V/100KHz	110	0.014	8.5	4.2	1R0
PNS60451R2YWF	1.2	1V/100KHz	100	0.016	8.0	4.0	1R2
PNS60451R3YWF	1.3	1V/100KHz	95	0.016	8.0	4.0	1R3
PNS60451R5YWF	1.5	1V/100KHz	65	0.018	7.0	3.7	1R5
PNS60451R8YWF	1.8	1V/100KHz	60	0.018	7.0	3.7	1R8
PNS60452R0YWF	2.0	1V/100KHz	52	0.021	6.0	3.5	2R0
PNS60452R2YWF	2.2	1V/100KHz	52	0.021	6.0	3.5	2R2
PNS60452R3YWF	2.3	1V/100KHz	52	0.021	6.0	3.5	2R3
PNS60453R0YWF	3.0	1V/100KHz	35	0.024	5.0	3.2	3R0
PNS60453R3YWF	3.3	1V/100KHz	32	0.024	5.0	3.2	3R3
PNS60453R6MWF	3.6	1V/100KHz	28	0.028	4.4	3.1	3R6
PNS60454R5MWF	4.5	1V/100KHz	25	0.031	4.0	3.0	4R5
PNS60454R7MWF	4.7	1V/100KHz	24	0.031	4.0	3.0	4R7
PNS60455R6MWF	5.6	1V/100KHz	23	0.036	3.9	2.9	5R6
PNS60456R3MWF	6.3	1V/100KHz	15	0.038	3.8	2.8	6R3
PNS60456R8MWF	6.8	1V/100KHz	14	0.038	3.8	2.8	6R8
PNS6045100MWF	10.0	1V/100KHz	12	0.047	3.0	2.5	100
PNS6045150MWF	15.0	1V/100KHz	10	0.077	2.3	1.9	150
PNS6045220MWF	22.0	1V/100KHz	7	0.115	1.9	1.5	220
PNS6045330MWF	33.0	1V/100KHz	6	0.145	1.5	1.4	330
PNS6045470MWF	47.0	1V/100KHz	5	0.220	1.3	1.1	470
PNS6045560MWF	56.0	1V/100KHz	4.5	0.310	1.1	1.0	560
PNS6045680MWF	68.0	1V/100KHz	4	0.330	1.0	0.90	680
PNS6045820MWF	82.0	1V/100KHz	3.9	0.460	0.90	0.80	820
PNS6045101MWF	100.0	1V/100KHz	3	0.500	0.80	0.70	101
PNS6045121MWF	120.0	1V/100KHz	3	0.620	0.75	0.70	121
PNS6045151MWF	150.0	1V/100KHz	2.8	0.800	0.70	0.65	151
PNS6045181MWF	180.0	1V/100KHz	2.6	0.930	0.65	0.60	181
PNS6045221MWF	220.0	1V/100KHz	2.4	1.200	0.60	0.50	221
PNS6045331MWF	330.0	1V/100KHz	2.2	1.800	0.50	0.40	331
PNS6045471MWF	470.0	1V/100KHz	2.0	2.000	0.40	0.35	471

Tolerance Code: M=±20%, Y=±30%

NOTE: Specifications subject to change without notice. Please check our website for latest information.

7. Soldering Specification

Mildly activated rosin fluxes are preferred. Our terminations are suitable for re-flow soldering systems. If hand soldering cannot be avoided, the preferred technique is the utilization of hot air soldering tools.

7-1. IR Soldering Reflow

Recommended temperature profiles for lead free re-flow soldering in Figure 1, Table 1.1 & 1.2 (J-STD-020F).

7-2. Iron Reflow

Products attachment with a soldering iron is discouraged due to the inherent process control limitations. In the event that a soldering iron must be employed the following precautions are recommended (Figure 2).

Note:

- (a) Preheat circuit and products to 150°C.
- (b) 350°C tip temperature (Max.)
- (c) Never contact the ceramic with the iron tip
- (d) 1.0mm tip diameter (Max.)
- (e) Use a 20 watt soldering iron with tip diameter of 1.0mm
- (f) Limit soldering time to 4~5 sec.

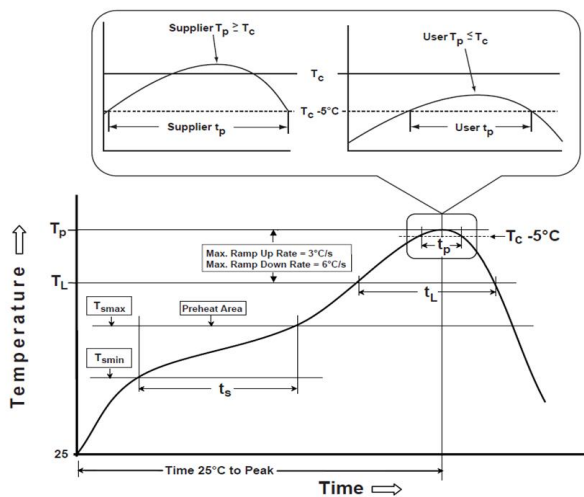

Reflow times: 3 times Max

Figure 1: IR Soldering Reflow

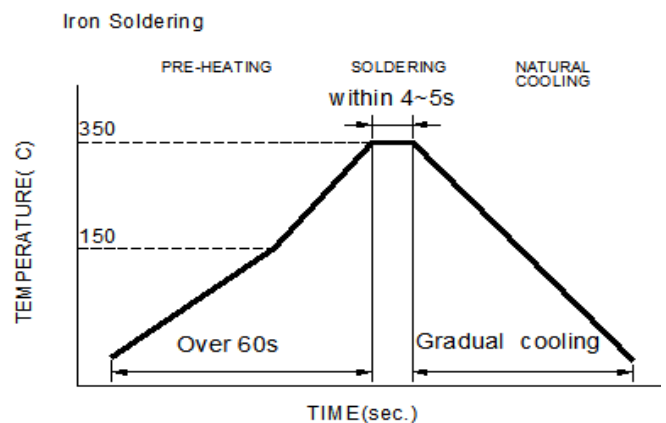

Iron Soldering times : 1 times max

Figure 2: Iron soldering temperature profiles

NOTE: Specifications subject to change without notice. Please check our website for latest information.

Table (1.1) Reflow Profiles

Profile Type:	Pb-Free Assembly
Preheat	
-Temperature Min (T_{smin})	150°C
-Temperature Max (T_{smax})	200°C
-Time (t_s) from (T_{smin} to T_{smax})	60-120seconds
Ramp-up rate (T_L to T_p)	3°C /second max.
Liquids temperature (T_L)	217°C
Time (t_L) maintained above T_L	60-150 seconds
Classification temperature (T_c)	See Table (1.2)
Time (t_p) at $T_c - 5^\circ\text{C}$ (T_p should be equal to or less than T_c .)	< 30 seconds
Ramp-down rate (T_p to T_L)	6°C /second max.
Time 25°C to peak temperature	8 minutes max.

T_p: maximum peak package body temperature, **T_c**: the classification temperature.

For user (customer) **T_p** should be equal to or less than **T_c**.

Table (1.2) Package Thickness/Volume and Classification Temperature (T_c)

	Package Thickness	Volume mm ³ <350	Volume mm ³ 350-2000	Volume mm ³ >2000
PB-Free Assembly	<1.6mm	260°C	260°C	260°C
	1.6-2.5mm	260°C	250°C	245°C
	≥2.5mm	250°C	245°C	245°C

Reflow is referred to standard IPC/JEDEC J-STD-020F.

7-3. Soldering Volume

Accordingly increasing the solder volume, the mechanical stress to product is also increased. Exceeding solder volume may cause the failure of mechanical or electrical performance. Solder shall be used not to be exceeded as shown in the Figure below.

Minimum fillet height = soldering thickness + 25% product height.

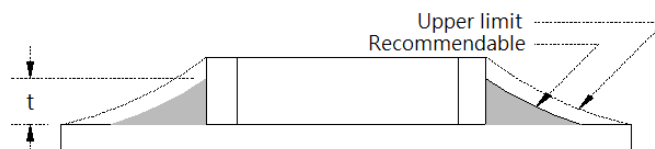

NOTE: Specifications subject to change without notice. Please check our website for latest information.

8. Packaging Information

8-1. Reel Dimension (Unit: mm)

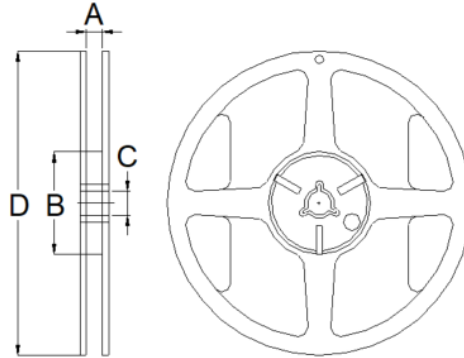

Type	A	B	C	D
13"x16mm	16.5 Ref	100.0 Ref	13.0 Ref	330.0 Ref

8-2. Tape Dimension (Unit: mm)

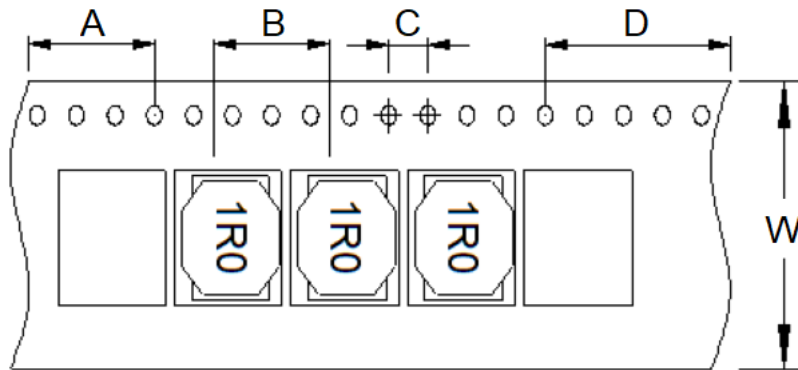

A	B	C	D	W
200	12	4	400	16

NOTE: Specifications subject to change without notice. Please check our website for latest information.

8-3. Packaging Quantity (Unit: Pcs)

Chip/ Reel	1,000
Carton	6,000

8-4. Tearing Off Force

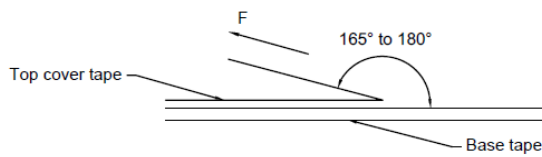

The force for tearing off cover tape is according to the follow table, in the arrow direction under the following conditions.

(Referenced ANSI/EIA-481-D-2008 of 4.11 standard)

Room Temp. (°C)	Room Humidity (%)	Room atm (hPa)	Tearing Speed (mm/min)
5~35	45~85	860~1060	300±10

Tape Size	8 mm	12 to 56 mm	72 mm or Wider
Tearing Off Force (grams)	10~100	10~130	10~150

Application Notice

1. Storage Conditions

To maintain the solderability of terminal electrodes:

- (a) Products meet IPC/JEDEC J-STD-020F standard-MSL, level 1.
- (b) Recommended products should be used within 12 months from the time of delivery.
- (c) The packaging material should be kept where no chlorine or sulfur exists in the air.

2. Transportation

- (a) Products should be handled with care to avoid damage or contamination from perspiration and skin oils.
- (b) Vacuum pick up is strongly recommended for individual components.
- (c) Bulk handling should ensure that abrasion and mechanical shock are minimized.

NOTE: Specifications subject to change without notice. Please check our website for latest information.