

## 1. Part No. Expression

**S D B 1 2 0 7 R 4 5 M Y F**

(a) (b) (c) (d) (e) (f)

- |                     |                    |
|---------------------|--------------------|
| (a) Series Code     | (d) Tolerance Code |
| (b) Dimension Code  | (e) Special Code   |
| (c) Inductance Code | (f) Packaging Code |

## 2. Configuration & Dimensions (Unit: mm)

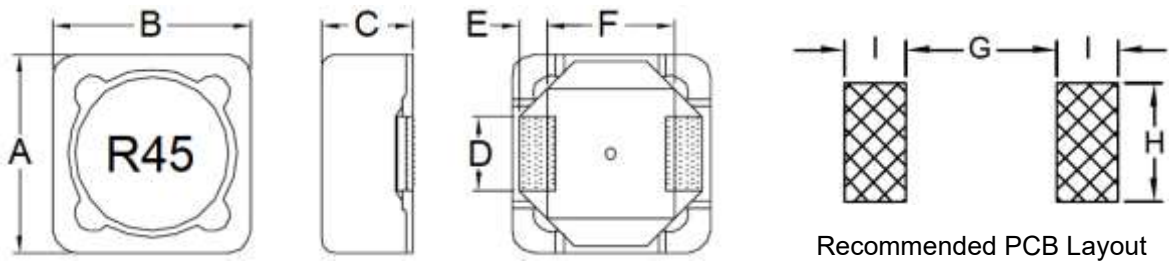

- Note:
1. The above PCB layout reference only.
  2. Marking: Inductance Code

A	B	C	D	E
12.5±0.3	12.5±0.3	8.0 Max	5.0±0.2	2.2±0.2
F	G	H	I	-
7.6±0.2	7.0 Ref	5.4 Ref	2.8 Ref	-

NOTE: Specifications subject to change without notice. Please check our website for latest information.

## 3. Schematic

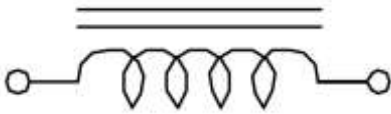

## 4. Material List

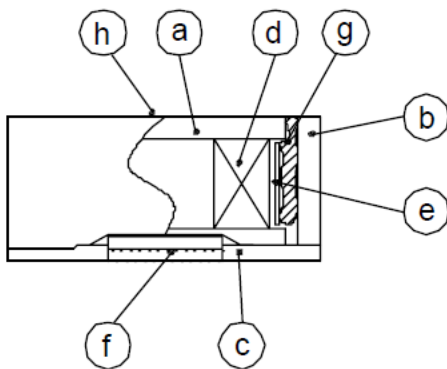

- (a) DR Core
- (b) RI Core
- (c) Base
- (d) Wire
- (e) Tape
- (f) Terminal
- (g) Adhesive
- (h) Ink

## 5. General Specifications

- (a) Operating Temp.:  $-40^{\circ}\text{C}$  to  $+125^{\circ}\text{C}$  (including self-temperature rise)
- (b) Storage Temp.:  $-40^{\circ}\text{C}$  to  $+125^{\circ}\text{C}$  (on board)
- (c) All test data referenced to  $25^{\circ}\text{C}$  ambient.
- (d) Heat Rated Current ( $I_{\text{rms}}$ ) will cause the coil temperature rise approximately  $\Delta T$  of  $40^{\circ}\text{C}$ .
- (e) Saturation Current ( $I_{\text{sat}}$ ) will cause inductance  $L_0$  to drop approximately 10%.
- (f) Rated Current: The lower value of  $I_{\text{sat}}$  and  $I_{\text{rms}}$ .
- (g) Storage Condition (Component in its packaging)
  - i) Temperature: Less than  $40^{\circ}\text{C}$
  - ii) Humidity: Less than 60% RH

NOTE: Specifications subject to change without notice. Please check our website for latest information.

## 6. Electrical Characteristics

Part Number	Inductance ( $\mu$ H) @0A $\pm 20\%$	Test Frequency	RDC (m $\Omega$ ) Max	I <sub>rms</sub> (A)	I <sub>sat</sub> (A)
SDB1207R45MYF	0.45	0.25V/100KHz	3.2	30.00	14.00
SDB1207R82MYF	0.82	0.25V/100KHz	5.0	22.00	12.00
SDB12071R5MYF	1.50	0.25V/100KHz	5.9	18.00	11.00
SDB12072R2MYF	2.20	0.25V/100KHz	7.0	15.00	10.00
SDB12073R3MYF	3.30	0.25V/100KHz	7.9	11.00	9.00
SDB12074R7MYF	4.70	0.25V/100KHz	9.5	10.00	8.50
SDB12075R6MYF	5.60	0.25V/100KHz	11.5	9.00	8.00
SDB12076R8MYF	6.80	0.25V/100KHz	12.5	8.00	7.50
SDB12078R2MYF	8.20	0.25V/100KHz	19.5	7.30	6.50
SDB1207100MYF	10.0	0.25V/10KHz	20.1	6.80	6.00
SDB1207120MYF	12.0	0.25V/10KHz	23.2	6.30	5.60
SDB1207150MYF	15.0	0.25V/10KHz	31.9	5.80	5.00
SDB1207180MYF	18.0	0.25V/10KHz	35.6	5.00	4.60
SDB1207220MYF	22.0	0.25V/10KHz	41.0	4.50	4.30
SDB1207270MYF	27.0	0.25V/10KHz	52.9	4.00	4.00
SDB1207330MYF	33.0	0.25V/10KHz	59.4	3.70	3.50
SDB1207390MYF	39.0	0.25V/10KHz	64.8	3.40	3.30
SDB1207470MYF	47.0	0.25V/10KHz	90.0	3.20	3.00
SDB1207560MYF	56.0	0.25V/10KHz	115	3.00	2.65
SDB1207680MYF	68.0	0.25V/10KHz	134	2.70	2.35
SDB1207820MYF	82.0	0.25V/10KHz	146	2.40	2.10
SDB1207101MYF	100	0.25V/10KHz	156	2.20	2.00
SDB1207121MYF	120	0.25V/10KHz	221	2.00	1.90
SDB1207151MYF	150	0.25V/10KHz	246	1.80	1.70
SDB1207181MYF	180	0.25V/10KHz	324	1.60	1.50
SDB1207221MYF	220	0.25V/10KHz	367	1.50	1.40

NOTE: Specifications subject to change without notice. Please check our website for latest information.

Part Number	Inductance ( $\mu$ H) @0A $\pm$ 20%	Test Frequency	RDC (m $\Omega$ ) Max	I <sub>rms</sub> (A)	I <sub>sat</sub> (A)
SDB1207271MYF	270	0.25V/10KHz	425	1.30	1.30
SDB1207331MYF	330	0.25V/10KHz	560	1.20	1.10
SDB1207391MYF	390	0.25V/10KHz	761	1.10	1.00
SDB1207471MYF	470	0.25V/10KHz	855	1.00	0.95
SDB1207561MYF	560	0.25V/10KHz	936	0.95	0.90
SDB1207681MYF	680	0.25V/10KHz	1296	0.85	0.80
SDB1207821MYF	820	0.25V/10KHz	1404	0.80	0.70
SDB1207102MYF	1000	0.25V/10KHz	1620	0.70	0.60

NOTE: Specifications subject to change without notice. Please check our website for latest information.

7. Characteristics Curve

@ TEMP. RISE VS. DC SUPERPOSITION RESPONSE CURVE

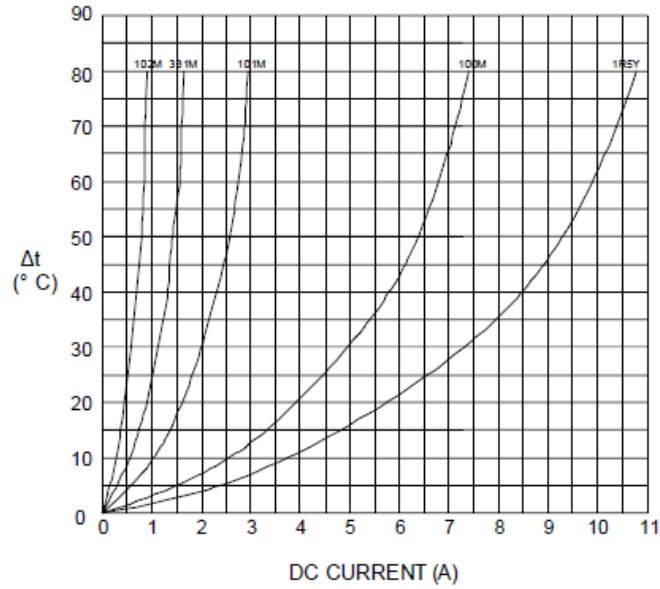

@ INDUCTANCE VS. FREQUENCY RESPONSE CURVE

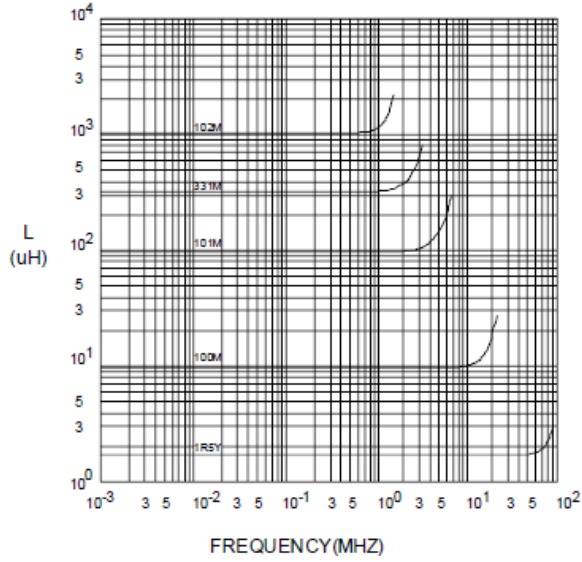

@ INDUCTANCE VS. DC SUPERPOSITION RESPONSE CURVE

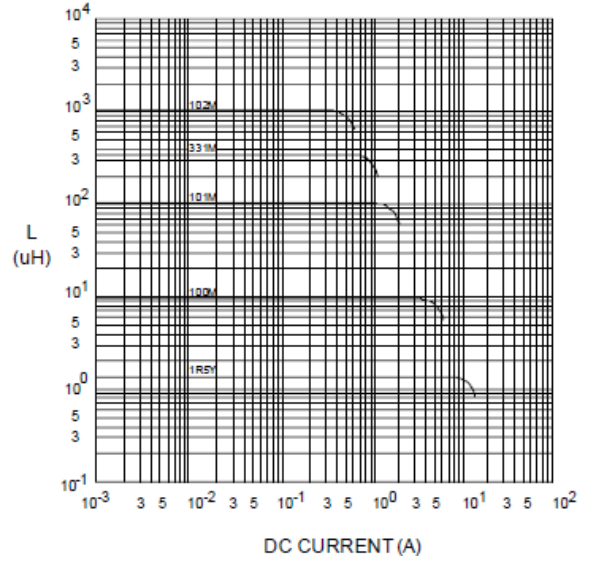

NOTE: Specifications subject to change without notice. Please check our website for latest information.

## 8. Soldering Specification

Mildly activated rosin fluxes are preferred. Our terminations are suitable for re-flow soldering systems. If hand soldering cannot be avoided, the preferred technique is the utilization of hot air soldering tools.

### 8-1. IR Soldering Reflow

Recommended temperature profiles for lead free re-flow soldering in Figure 1, Table 1.1 & 1.2 (J-STD-020F).

### 8-2. Iron Reflow

Products attachment with a soldering iron is discouraged due to the inherent process control limitations. In the event that a soldering iron must be employed the following precautions are recommended (Figure 2).

Note:

- (a) Preheat circuit and products to 150°C.
- (b) 350°C tip temperature (Max.)
- (c) Never contact the ceramic with the iron tip
- (d) 1.0mm tip diameter (Max.)
- (e) Use a 20 watt soldering iron with tip diameter of 1.0mm
- (f) Limit soldering time to 4~5 sec.

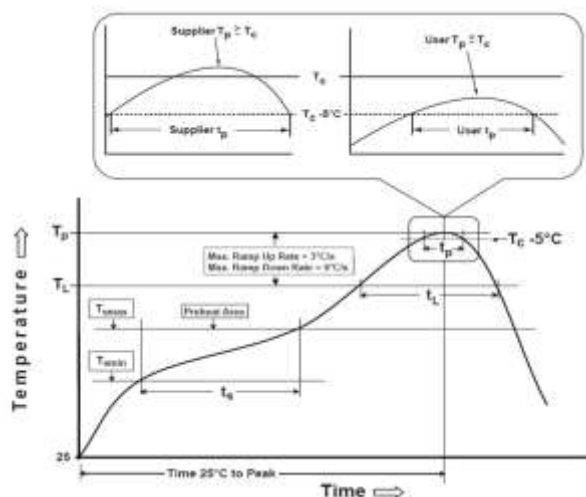

Reflow times: 3 times Max

Figure 1: IR Soldering Reflow

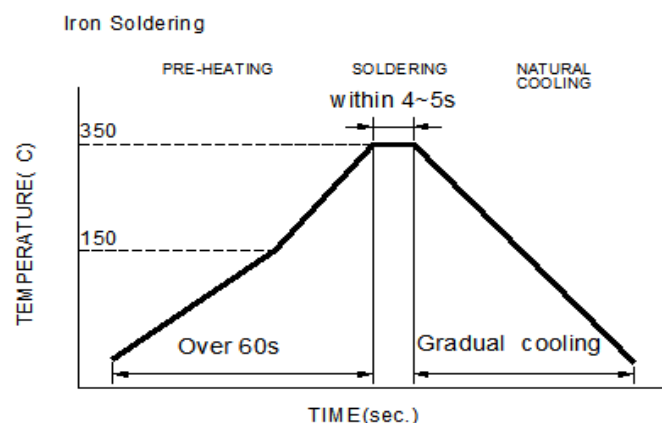

Iron Soldering times : 1 times max

Figure 2: Iron soldering temperature profiles

NOTE: Specifications subject to change without notice. Please check our website for latest information.

**Table (1.1) Reflow Profiles**

Profile Type:	Pb-Free Assembly
Preheat	
-Temperature Min ( $T_{smin}$ )	150°C
-Temperature Max ( $T_{smax}$ )	200°C
-Time ( $t_s$ ) from ( $T_{smin}$ to $T_{smax}$ )	60-120seconds
Ramp-up rate ( $T_L$ to $T_p$ )	3°C /second max.
Liquids temperature ( $T_L$ )	217°C
Time ( $t_L$ ) maintained above $T_L$	60-150 seconds
Classification temperature ( $T_c$ )	See Table (1.2)
Time ( $t_p$ ) at $T_c - 5^\circ\text{C}$ ( $T_p$ should be equal to or less than $T_c$ .)	< 30 seconds
Ramp-down rate ( $T_p$ to $T_L$ )	6°C /second max.
Time 25°C to peak temperature	8 minutes max.

**T<sub>p</sub>**: maximum peak package body temperature, **T<sub>c</sub>**: the classification temperature.

For user (customer) **T<sub>p</sub>** should be equal to or less than **T<sub>c</sub>**.

**Table (1.2) Package Thickness/Volume and Classification Temperature ( $T_c$ )**

	Package Thickness	Volume mm <sup>3</sup> <350	Volume mm <sup>3</sup> 350-2000	Volume mm <sup>3</sup> >2000
PB-Free Assembly	<1.6mm	260°C	260°C	260°C
	1.6-2.5mm	260°C	250°C	245°C
	≥2.5mm	250°C	245°C	245°C

Reflow is referred to standard IPC/JEDEC J-STD-020F.

### 8-3. Soldering Volume

Accordingly increasing the solder volume, the mechanical stress to product is also increased. Exceeding solder volume may cause the failure of mechanical or electrical performance. Solder shall be used not to be exceeded as shown in the Figure below.

Minimum fillet height = soldering thickness + 25% product height.



NOTE: Specifications subject to change without notice. Please check our website for latest information.

9. Packaging Information

9-1. Reel Dimension (Unit: mm)

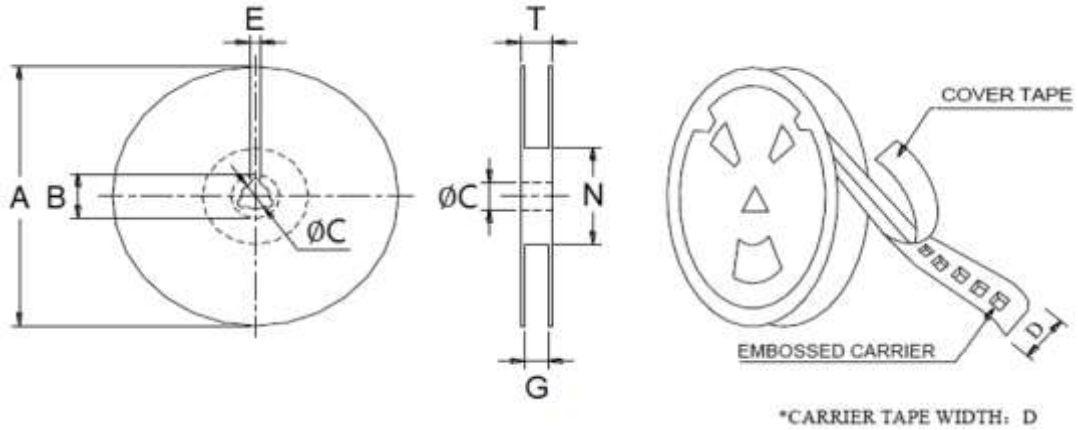

Type	A	B	C	D
	330.0 Ref	21.0 Ref	13.0 Ref	24.0 Ref
13"x24mm	E	G	N	T
	2.0 Ref	26.0 Max	100.0 Min	30.4 Ref

9-2. Tape Dimension (Unit: mm)

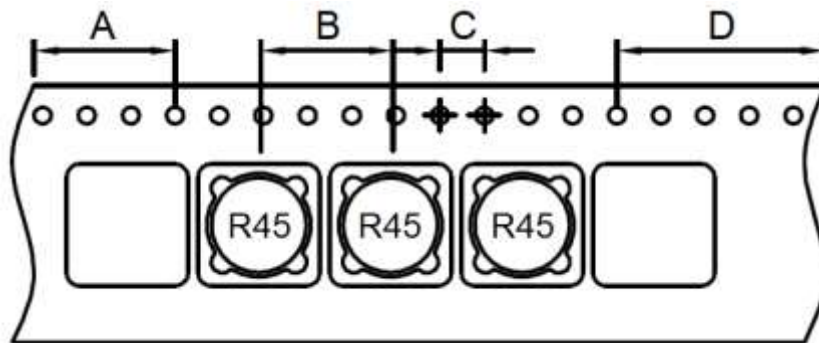

A	B	C	D
200	16	4	400

NOTE: Specifications subject to change without notice. Please check our website for latest information.

### 9-3. Packaging Quantity & G.W & Size

INNER : REEL		OUTER : CARTON		
QTY(PCS)	G.W(gw)	QTY(PCS)	G.W(Kg)	SIZE(cm)
400	2,100	1,600	11.9	36x35.5x14.3

### 9-4. Tearing Off Force

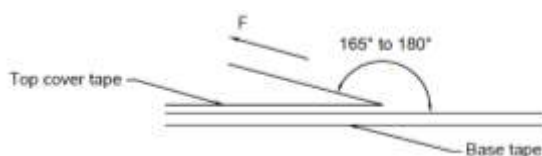

The force for tearing off cover tape is according to the follow table, in the arrow direction under the following conditions.

(Referenced ANSI/EIA-481-D-2008 of 4.11 standard)

Room Temp. (°C)	Room Humidity (%)	Room atm (hPa)	Tearing Speed (mm/min)
5~35	45~85	860~1060	300±10

Tape Size	8 mm	12 to 56 mm	72 mm or Wider
Tearing Off Force (grams)	10~100	10~130	10~150

## Application Notice

#### 1. Storage Conditions

To maintain the solderability of terminal electrodes:

- (a) Products meet IPC/JEDEC J-STD-020F standard-MSL, level 1.
- (b) Recommended products should be used within 12 months from the time of delivery.
- (c) The packaging material should be kept where no chlorine or sulfur exists in the air.

#### 2. Transportation

- (a) Products should be handled with care to avoid damage or contamination from perspiration and skin oils.
- (b) Vacuum pick up is strongly recommended for individual components.
- (c) Bulk handling should ensure that abrasion and mechanical shock are minimized.

NOTE: Specifications subject to change without notice. Please check our website for latest information.