

## 1. Part No. Expression

**SSB06051R0MZF**

(a) (b) (c) (d) (e) (f)

- (a) Series Code
- (b) Dimension Code
- (c) Inductance Code
- (d) Tolerance Code
- (e) Special Code
- (f) Packaging Code

## 2. Configuration & Dimensions (Unit: mm)

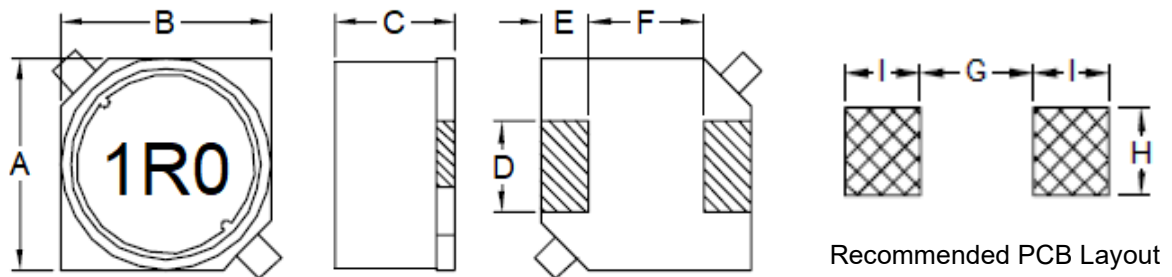

Note: 1. The above PCB layout reference only.

A	B	C	D	E
6.0±0.3	6.0±0.3	4.9±0.3	2.0±0.2	1.5±0.2
F	G	H	I	-
3.0±0.2	2.8 Ref	2.2 Ref	1.9 Ref	-

## 3. Schematic

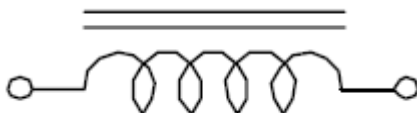

NOTE: Specifications subject to change without notice. Please check our website for latest information.

## 4. Material List

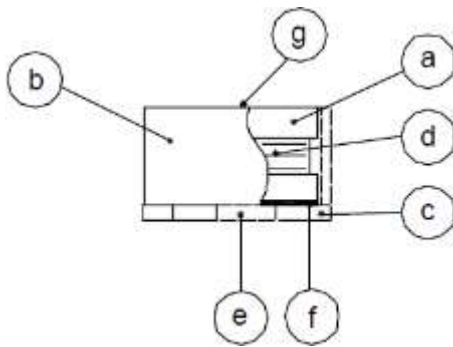

- (a) DR Core
- (b) RI Core
- (c) Base
- (d) Wire
- (e) Terminal
- (f) Adhesive
- (g) Ink

## 5. General Specifications

- (a) Operating Temp.: -40°C to +85°C (including self-temperature rise)
- (b) All test data referenced to 25°C ambient.
- (c) Heat Rated Current (I<sub>rms</sub>) will cause the coil temperature rise ΔT of 40°C Max.
- (d) Saturation Current (I<sub>sat</sub>) will cause inductance L<sub>0</sub> to drop 10% Max.
- (e) Rated Current: The lower value of I<sub>sat</sub> and I<sub>rms</sub>.
- (f) Resistance to Solder Heat: 260°C, 10Sec.
- (g) Storage Condition (Component in its packaging)
  - i) Temperature: -10°C to 40°C
  - ii) Humidity: Less than 60% RH

## 6. Electrical Characteristics

Part Number	Inductance (uH) ±20%	Test Frequency	RDC (mΩ) Max	IDC (A) Max
SSB06051R0MZF	1.0	1V/100KHz	23	2.70
SSB06051R5MZF	1.5	1V/100KHz	26	2.30
SSB06052R2MZF	2.2	1V/100KHz	28	1.90
SSB06053R3MZF	3.3	1V/100KHz	35	1.80
SSB06054R7MZF	4.7	1V/100KHz	40	1.40

NOTE: Specifications subject to change without notice. Please check our website for latest information.

Part Number	Inductance ( $\mu$ H) $\pm 20\%$	Test Frequency	RDC (m $\Omega$ ) Max	IDC (A) Max
SSB06056R8MZF	6.8	1V/100KHz	45	1.20
SSB0605100MZF	10.0	1V/100KHz	60	1.00
SSB0605120MZF	12.0	1V/100KHz	65	0.90
SSB0605150MZF	15.0	1V/100KHz	70	0.80
SSB0605180MZF	18.0	1V/100KHz	95	0.70
SSB0605220MZF	22.0	1V/100KHz	110	0.65
SSB0605270MZF	27.0	1V/100KHz	120	0.60
SSB0605330MZF	33.0	1V/100KHz	165	0.55
SSB0605390MZF	39.0	1V/100KHz	180	0.48
SSB0605470MZF	47.0	1V/100KHz	200	0.45
SSB0605560MZF	56.0	1V/100KHz	255	0.40
SSB0605680MZF	68.0	1V/100KHz	285	0.37
SSB0605820MZF	82.0	1V/100KHz	390	0.35
SSB0605101MZF	100.0	1V/100KHz	420	0.30
SSB0605121MZF	120.0	1V/100KHz	470	0.28
SSB0605151MZF	150.0	1V/100KHz	630	0.25
SSB0605181MZF	180.0	1V/100KHz	720	0.22
SSB0605221MZF	220.0	1V/100KHz	820	0.20
SSB0605271MZF	270.0	1V/100KHz	1100	0.18
SSB0605331MZF	330.0	1V/100KHz	1200	0.17
SSB0605391MZF	390.0	1V/100KHz	1700	0.16
SSB0605471MZF	470.0	1V/100KHz	1900	0.14
SSB0605561MZF	560.0	1V/100KHz	2150	0.13
SSB0605681MZF	680.0	1V/100KHz	3300	0.12
SSB0605821MZF	820.0	1V/100KHz	3650	0.11
SSB0605102MZF	1000.0	1V/100KHz	4150	0.10

NOTE: Specifications subject to change without notice. Please check our website for latest information.

## 7. Characteristics Curves

@ TEMP. RISE VS. DC SUPERPOSITION RESPONSE CURVE

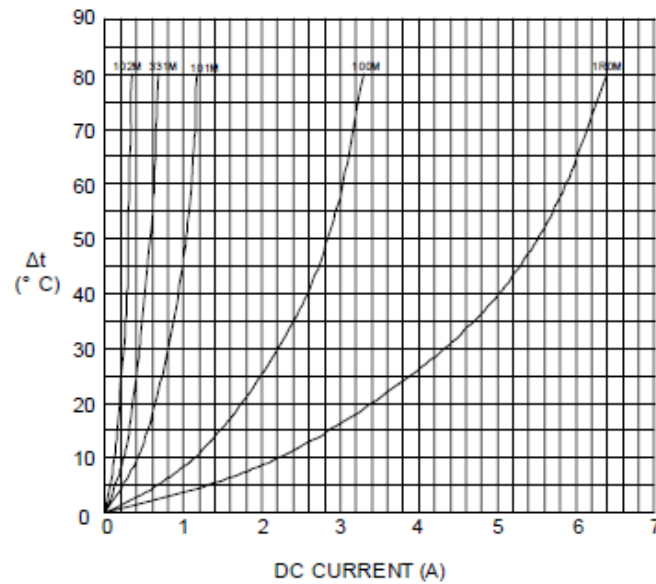

@ INDUCTANCE VS. FREQUENCY RESPONSE CURVE

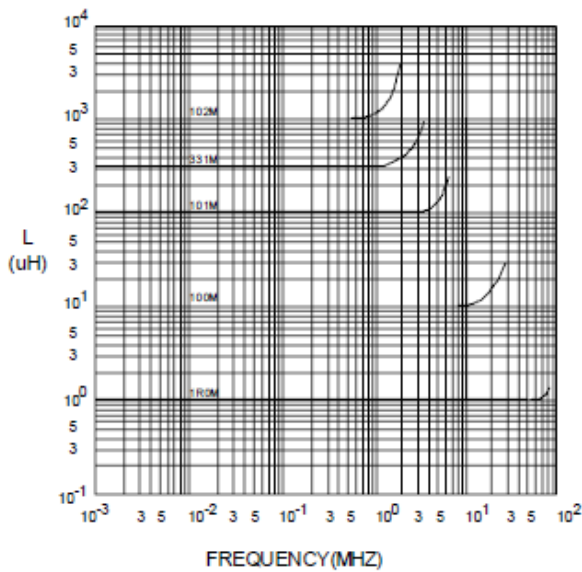

@ INDUCTANCE VS. DC SUPERPOSITION RESPONSE CURVE

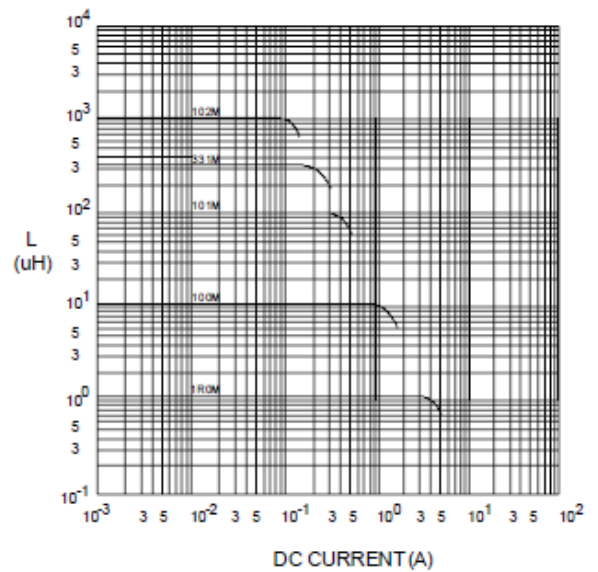

NOTE: Specifications subject to change without notice. Please check our website for latest information.

### 8. Soldering Specification

Mildly activated rosin fluxes are preferred. Our terminations are suitable for re-flow soldering systems. If hand soldering cannot be avoided, the preferred technique is the utilization of hot air soldering tools.

#### 8-1. IR Soldering Reflow

Recommended temperature profiles for lead free re-flow soldering in Figure 1, Table 1.1 & 1.2 (J-STD-020F).

#### 8-2. Iron Reflow

Products attachment with a soldering iron is discouraged due to the inherent process control limitations. In the event that a soldering iron must be employed the following precautions are recommended (Figure 2).

Note:

- (a) Preheat circuit and products to 150°C.
- (b) 350°C tip temperature (Max.)
- (c) Never contact the ceramic with the iron tip
- (d) 1.0mm tip diameter (Max.)
- (e) Use a 20 watt soldering iron with tip diameter of 1.0mm
- (f) Limit soldering time to 4~5 sec.

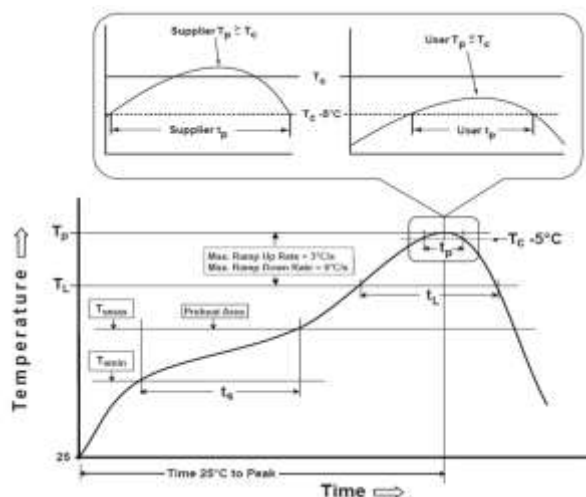

Reflow times: 3 times Max

Figure 1: IR Soldering Reflow

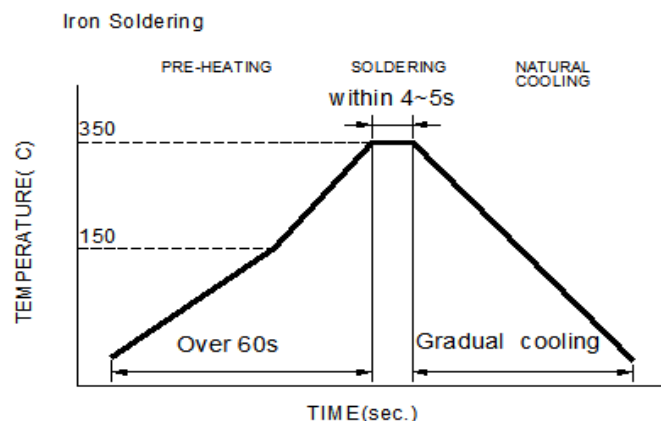

Iron Soldering times : 1 times max

Figure 2: Iron soldering temperature profiles

NOTE: Specifications subject to change without notice. Please check our website for latest information.

**Table (1.1) Reflow Profiles**

Profile Type:	Pb-Free Assembly
Preheat	
-Temperature Min ( $T_{smin}$ )	150°C
-Temperature Max ( $T_{smax}$ )	200°C
-Time ( $t_s$ ) from ( $T_{smin}$ to $T_{smax}$ )	60-120seconds
Ramp-up rate ( $T_L$ to $T_p$ )	3°C /second max.
Liquids temperature ( $T_L$ )	217°C
Time ( $t_L$ ) maintained above $T_L$	60-150 seconds
Classification temperature ( $T_c$ )	See Table (1.2)
Time ( $t_p$ ) at $T_c - 5^\circ\text{C}$ ( $T_p$ should be equal to or less than $T_c$ .)	< 30 seconds
Ramp-down rate ( $T_p$ to $T_L$ )	6°C /second max.
Time 25°C to peak temperature	8 minutes max.

**T<sub>p</sub>**: maximum peak package body temperature, **T<sub>c</sub>**: the classification temperature.

For user (customer) **T<sub>p</sub>** should be equal to or less than **T<sub>c</sub>**.

**Table (1.2) Package Thickness/Volume and Classification Temperature ( $T_c$ )**

	Package Thickness	Volume mm <sup>3</sup> <350	Volume mm <sup>3</sup> 350-2000	Volume mm <sup>3</sup> >2000
PB-Free Assembly	<1.6mm	260°C	260°C	260°C
	1.6-2.5mm	260°C	250°C	245°C
	≥2.5mm	250°C	245°C	245°C

Reflow is referred to standard IPC/JEDEC J-STD-020F.

### 8-3. Soldering Volume

Accordingly increasing the solder volume, the mechanical stress to product is also increased. Exceeding solder volume may cause the failure of mechanical or electrical performance. Solder shall be used not to be exceeded as shown in the Figure below.

Minimum fillet height = soldering thickness + 25% product height.



NOTE: Specifications subject to change without notice. Please check our website for latest information.

## 9. Packaging Information

### 9-1. Reel Dimension (Unit: mm)

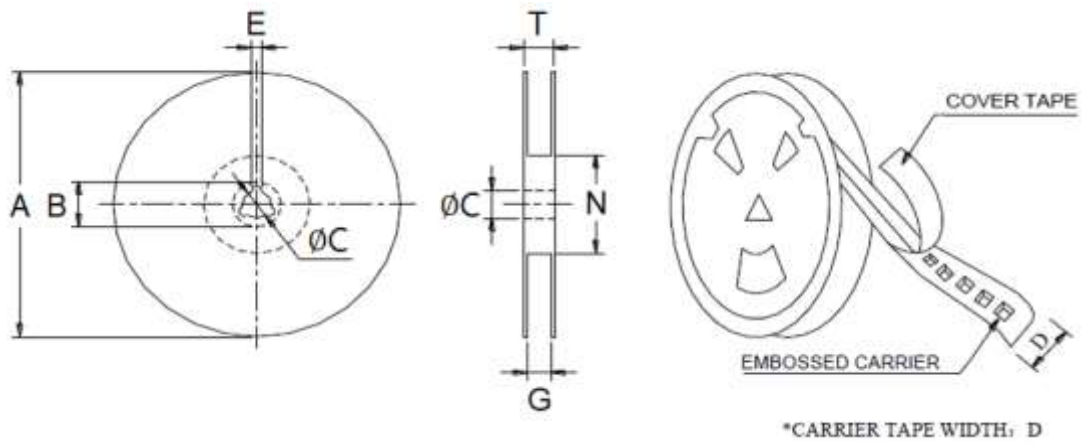

Type	A	B	C	D	G	N	T
13"x16mm	330.0 Ref	21.0 Ref	13.0 Ref	16.0 Ref	18.0 Max	50.0 Min	22.4 Ref

### 9-2. Tape Dimension (Unit: mm)

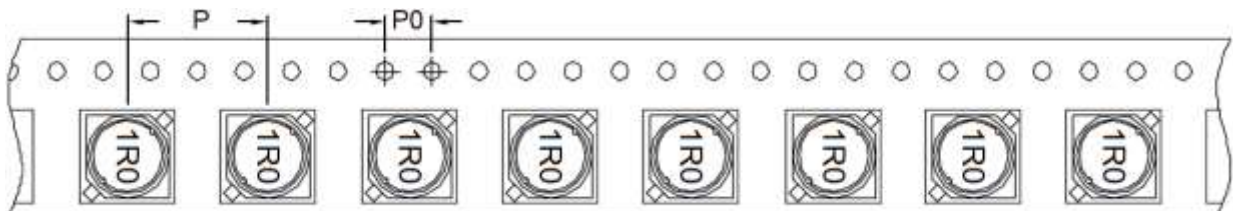

P	P0
12	4

NOTE: Specifications subject to change without notice. Please check our website for latest information.

### 9-3. Packaging Quantity (Unit: Pcs)

Inner: Reel			Outer: Carton		
Qty (pcs)	G.W (gw)	Style	Qty (pcs)	G.W(kg)	Size (cm)
1,000	1,100	13-16	6,000	10.1	40 x 40 x 24

### 9-4. Tearing Off Force

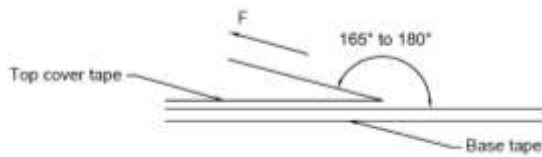

The force for tearing off cover tape is according to the follow table, in the arrow direction under the following conditions.

(Referenced ANSI/EIA-481-D-2008 of 4.11 standard)

Room Temp. (°C)	Room Humidity (%)	Room atm (hPa)	Tearing Speed (mm/min)
5~35	45~85	860~1060	300±10

Tape Size	8 mm	12 to 56 mm	72 mm or Wider
Tearing Off Force (grams)	10~100	10~130	10~150

## Application Notice

#### 1. Storage Conditions

To maintain the solderability of terminal electrodes:

- (a) Products meet IPC/JEDEC J-STD-020F standard-MSL, level 1.
- (b) Recommended products should be used within 12 months from the time of delivery.
- (c) The packaging material should be kept where no chlorine or sulfur exists in the air.

#### 2. Transportation

- (a) Products should be handled with care to avoid damage or contamination from perspiration and skin oils.
- (b) Vacuum pick up is strongly recommended for individual components.
- (c) Bulk handling should ensure that abrasion and mechanical shock are minimized.

NOTE: Specifications subject to change without notice. Please check our website for latest information.