

## 1. Part No. Expression

**SSC05032R5YZF**

(a) (b) (c) (d) (e) (f)

- |                     |                    |
|---------------------|--------------------|
| (a) Series Code     | (d) Tolerance Code |
| (b) Dimension Code  | (e) Special Code   |
| (c) Inductance Code | (f) Packaging Code |

## 2. Configuration & Dimensions (Unit: mm)

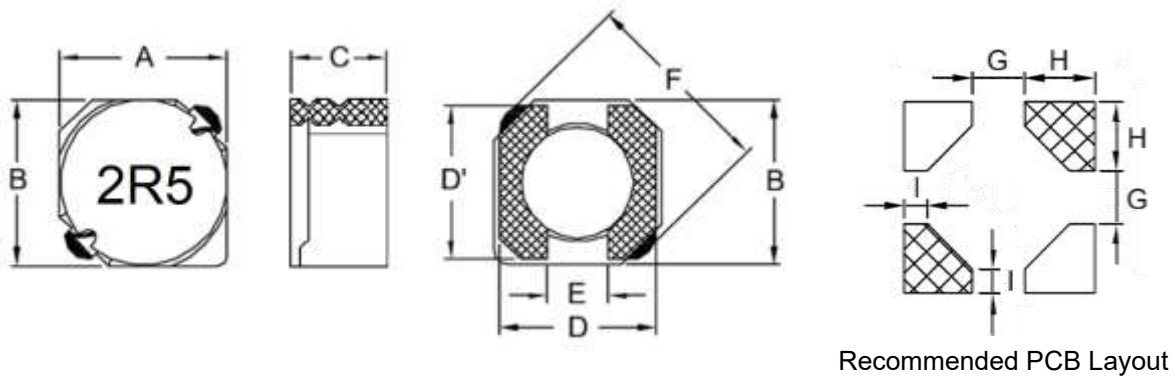

- Note: 1. The above PCB layout reference only.  
2. Marking: Inductance Code

A	B	C	D	D'
5.70±0.30	5.70±0.30	3.00 Max	5.50 Ref	5.50 Ref
E	F	G	H	I
2.00 Ref	8.20 Max	2.20 Ref	2.05 Ref	0.85 Ref

NOTE: Specifications subject to change without notice. Please check our website for latest information.

## 3. Schematic

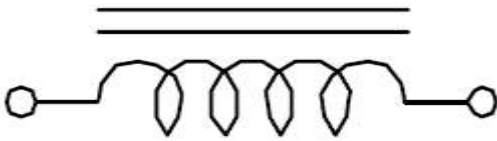

## 4. Material List

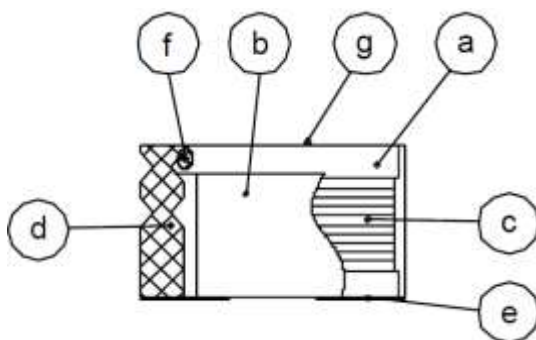

- (a) DR Core
- (b) RI Core
- (c) Wire
- (d) Terminal
- (e) Adhesive
- (f) Adhesive
- (g) Ink

## 5. General Specifications

- (a) Operating Temp.: -40°C to +95°C (including self-temperature rise)
- (b) All test data referenced to 25°C ambient.
- (c) Heat Rated Current (I<sub>rms</sub>) will cause the coil temperature rise  $\Delta T$  of 30°C Max.
- (d) Saturation Current (I<sub>sat</sub>) will cause inductance L<sub>0</sub> to drop 35% Max.
- (e) Rated Current: The lower value of I<sub>sat</sub> and I<sub>rms</sub>.
- (f) Resistance to solder heat: 260° C, 10 secs.
- (g) Storage Condition (Component in its packaging)
  - i) Temperature: -10°C to 40°C
  - ii) Humidity: Less than 60% RH

NOTE: Specifications subject to change without notice. Please check our website for latest information.

## 6. Electrical Characteristics

Part Number	Inductance ( $\mu$ H) @0A $\pm$ 30%	Test Frequency	DCR (m $\Omega$ ) Max	IDC (A) Max
SSC05032R5YZF	2.5	0.5V/10KHz	18	2.60
SSC05033R0YZF	3.0	0.5V/10KHz	24	2.40
SSC05034R2YZF	4.2	0.5V/10KHz	31	2.20
SSC05035R3YZF	5.3	0.5V/10KHz	38	1.90
SSC05036R2YZF	6.2	0.5V/10KHz	45	1.80
SSC05038R2YZF	8.2	0.5V/10KHz	53	1.60
SSC0503100YZF	10.0	0.5V/10KHz	65	1.30
SSC0503120YZF	12.0	0.5V/10KHz	76	1.20
SSC0503150YZF	15.0	0.5V/10KHz	103	1.10
SSC0503180YZF	18.0	0.5V/10KHz	110	1.00
SSC0503220YZF	22.0	0.5V/10KHz	122	0.90
SSC0503270YZF	27.0	0.5V/10KHz	175	0.85
SSC0503330YZF	33.0	0.5V/10KHz	189	0.75
SSC0503390YZF	39.0	0.5V/10KHz	212	0.70
SSC0503470YZF	47.0	0.5V/10KHz	250	0.62
SSC0503560YZF	56.0	0.5V/10KHz	305	0.58
SSC0503680YZF	68.0	0.5V/10KHz	355	0.52
SSC0503820YZF	82.0	0.5V/10KHz	463	0.46
SSC0503101YZF	100.0	0.5V/10KHz	520	0.42

NOTE: Specifications subject to change without notice. Please check our website for latest information.

## 7. Characteristics Curves

@ TEMP. RISE VS. DC SUPERPOSITION RESPONSE CURVE

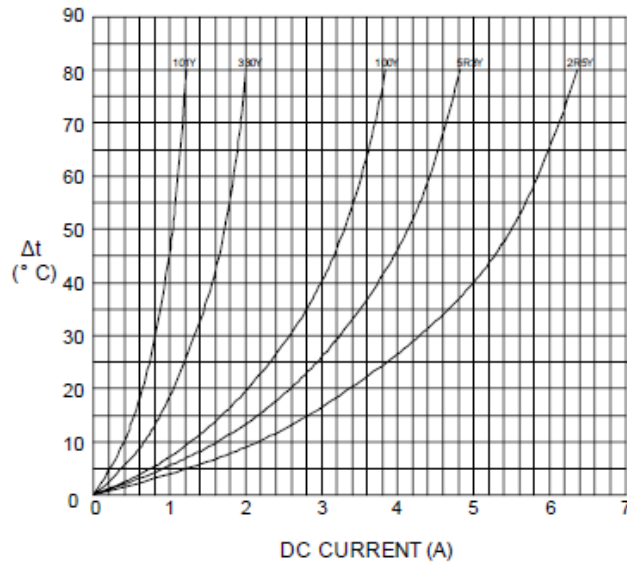

@ INDUCTANCE VS. FREQUENCY RESPONSE CURVE

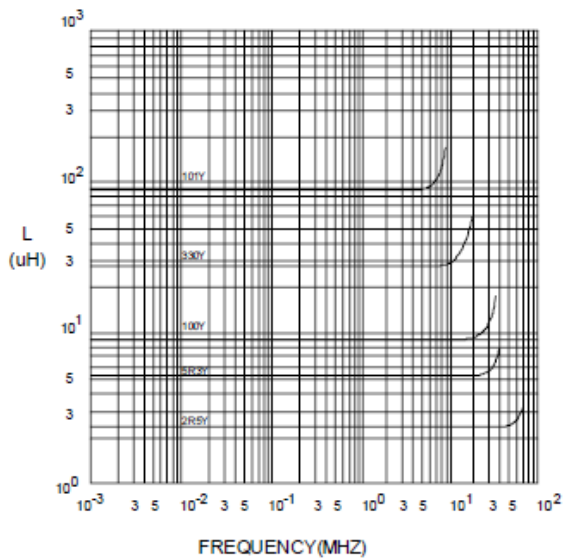

@ INDUCTANCE VS. DC SUPERPOSITION RESPONSE CURVE

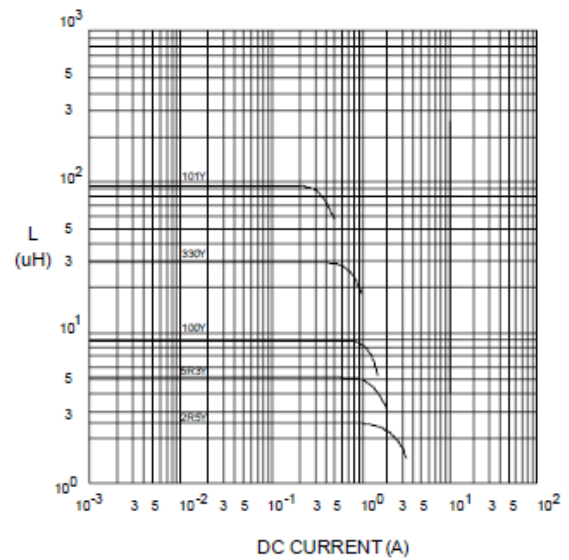

NOTE: Specifications subject to change without notice. Please check our website for latest information.

### 8. Soldering Specification

Mildly activated rosin fluxes are preferred. Our terminations are suitable for re-flow soldering systems. If hand soldering cannot be avoided, the preferred technique is the utilization of hot air soldering tools.

#### 8-1. IR Soldering Reflow

Recommended temperature profiles for lead free re-flow soldering in Figure 1, Table 1.1 & 1.2 (J-STD-020F).

#### 8-2. Iron Reflow

Products attachment with a soldering iron is discouraged due to the inherent process control limitations. In the event that a soldering iron must be employed the following precautions are recommended (Figure 2).

Note:

- (a) Preheat circuit and products to 150°C.
- (b) 350°C tip temperature (Max.)
- (c) Never contact the ceramic with the iron tip
- (d) 1.0mm tip diameter (Max.)
- (e) Use a 20 watt soldering iron with tip diameter of 1.0mm
- (f) Limit soldering time to 4~5 sec.



Reflow times: 3 times Max

Figure 1: IR Soldering Reflow

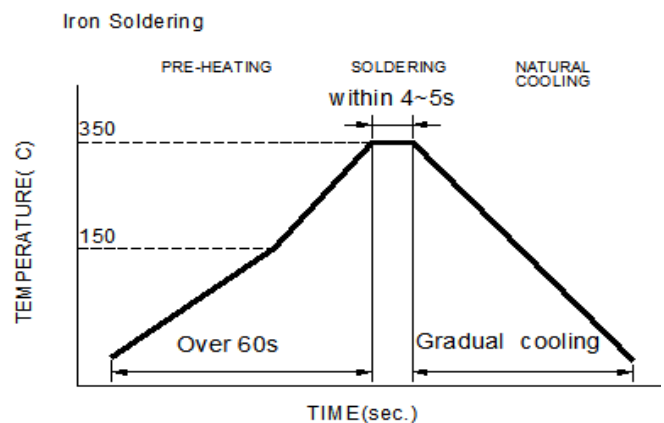

Iron Soldering times : 1 times max

Figure 2: Iron soldering temperature profiles

NOTE: Specifications subject to change without notice. Please check our website for latest information.

**Table (1.1) Reflow Profiles**

Profile Type:	Pb-Free Assembly
Preheat	
-Temperature Min ( $T_{smin}$ )	150°C
-Temperature Max ( $T_{smax}$ )	200°C
-Time ( $t_s$ ) from ( $T_{smin}$ to $T_{smax}$ )	60-120seconds
Ramp-up rate ( $T_L$ to $T_p$ )	3°C /second max.
Liquids temperature ( $T_L$ )	217°C
Time ( $t_L$ ) maintained above $T_L$	60-150 seconds
Classification temperature ( $T_c$ )	See Table (1.2)
Time ( $t_p$ ) at $T_c - 5^\circ\text{C}$ ( $T_p$ should be equal to or less than $T_c$ .)	< 30 seconds
Ramp-down rate ( $T_p$ to $T_L$ )	6°C /second max.
Time 25°C to peak temperature	8 minutes max.

**T<sub>p</sub>**: maximum peak package body temperature, **T<sub>c</sub>**: the classification temperature.

For user (customer) **T<sub>p</sub>** should be equal to or less than **T<sub>c</sub>**.

**Table (1.2) Package Thickness/Volume and Classification Temperature ( $T_c$ )**

	Package Thickness	Volume mm <sup>3</sup> <350	Volume mm <sup>3</sup> 350-2000	Volume mm <sup>3</sup> >2000
PB-Free Assembly	<1.6mm	260°C	260°C	260°C
	1.6-2.5mm	260°C	250°C	245°C
	≥2.5mm	250°C	245°C	245°C

Reflow is referred to standard IPC/JEDEC J-STD-020F.

### 8-3. Soldering Volume

Accordingly increasing the solder volume, the mechanical stress to product is also increased. Exceeding solder volume may cause the failure of mechanical or electrical performance. Solder shall be used not to be exceeded as shown in the Figure below.

Minimum fillet height = soldering thickness + 25% product height.



NOTE: Specifications subject to change without notice. Please check our website for latest information.

## 9. Packaging Information

### 9-1. Reel Dimension (Unit: mm)

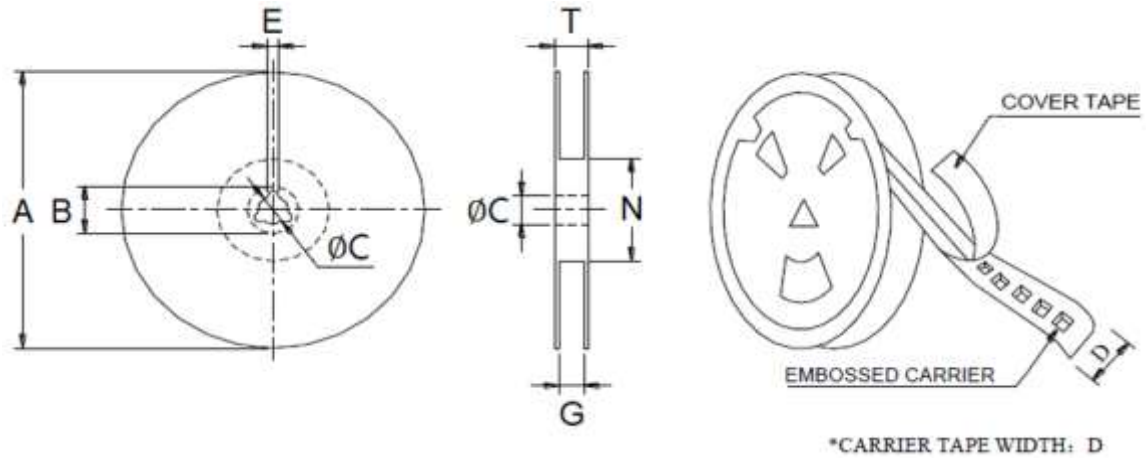

Type	A	B	C	D
	330.0 Ref	21.0 Ref	13.0 Ref	16.0 Ref
13"x16mm	E	G	N	T
	2.0 Ref	18.0 Max	50.0 Min	22.4 Ref

### 9-2. Tape Dimension (Unit: mm)

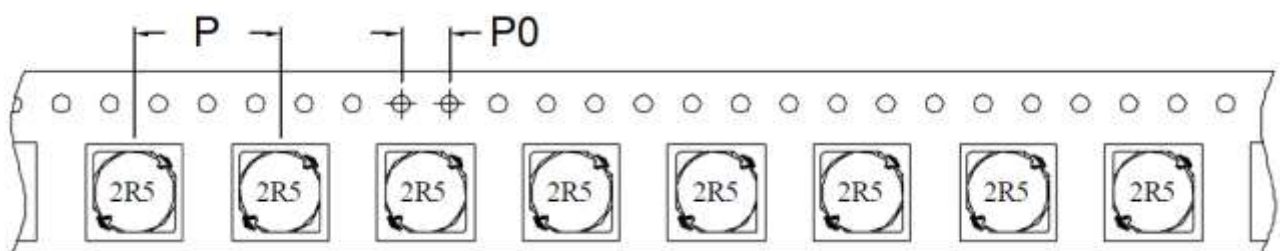

P	P0
12	4

NOTE: Specifications subject to change without notice. Please check our website for latest information.

### 9-3. Packaging Quantity (Unit: Pcs)

INNER : REEL			OUTER : CARTON		
QTY(PCS)	G.W(gw)	STYLE	QTY(PCS)	G.W.(Kg)	SIZE(cm)
1,500	1,800	13-16	9,000	14.3	40 x 40 x 24

### 9-4. Tearing Off Force

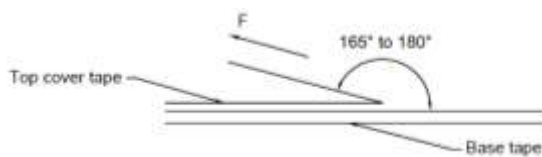

The force for tearing off cover tape is according to the follow table, in the arrow direction under the following conditions.

(Referenced ANSI/EIA-481-D-2008 of 4.11 standard)

Room Temp. (°C)	Room Humidity (%)	Room atm (hPa)	Tearing Speed (mm/min)
5~35	45~85	860~1060	300±10

Tape Size	8 mm	12 to 56 mm	72 mm or Wider
Tearing Off Force (grams)	10~100	10~130	10~150

## Application Notice

#### 1. Storage Conditions

To maintain the solderability of terminal electrodes:

- (a) Products meet IPC/JEDEC J-STD-020F standard-MSL, level 1.
- (b) Recommended products should be used within 12 months from the time of delivery.
- (c) The packaging material should be kept where no chlorine or sulfur exists in the air.

#### 2. Transportation

- (a) Products should be handled with care to avoid damage or contamination from perspiration and skin oils.
- (b) Vacuum pick up is strongly recommended for individual components.
- (c) Bulk handling should ensure that abrasion and mechanical shock are minimized.

NOTE: Specifications subject to change without notice. Please check our website for latest information.